

修飾圖面
樣品圖面
參考圖面
承認圖面
更新圖面

1

2

3

4

5

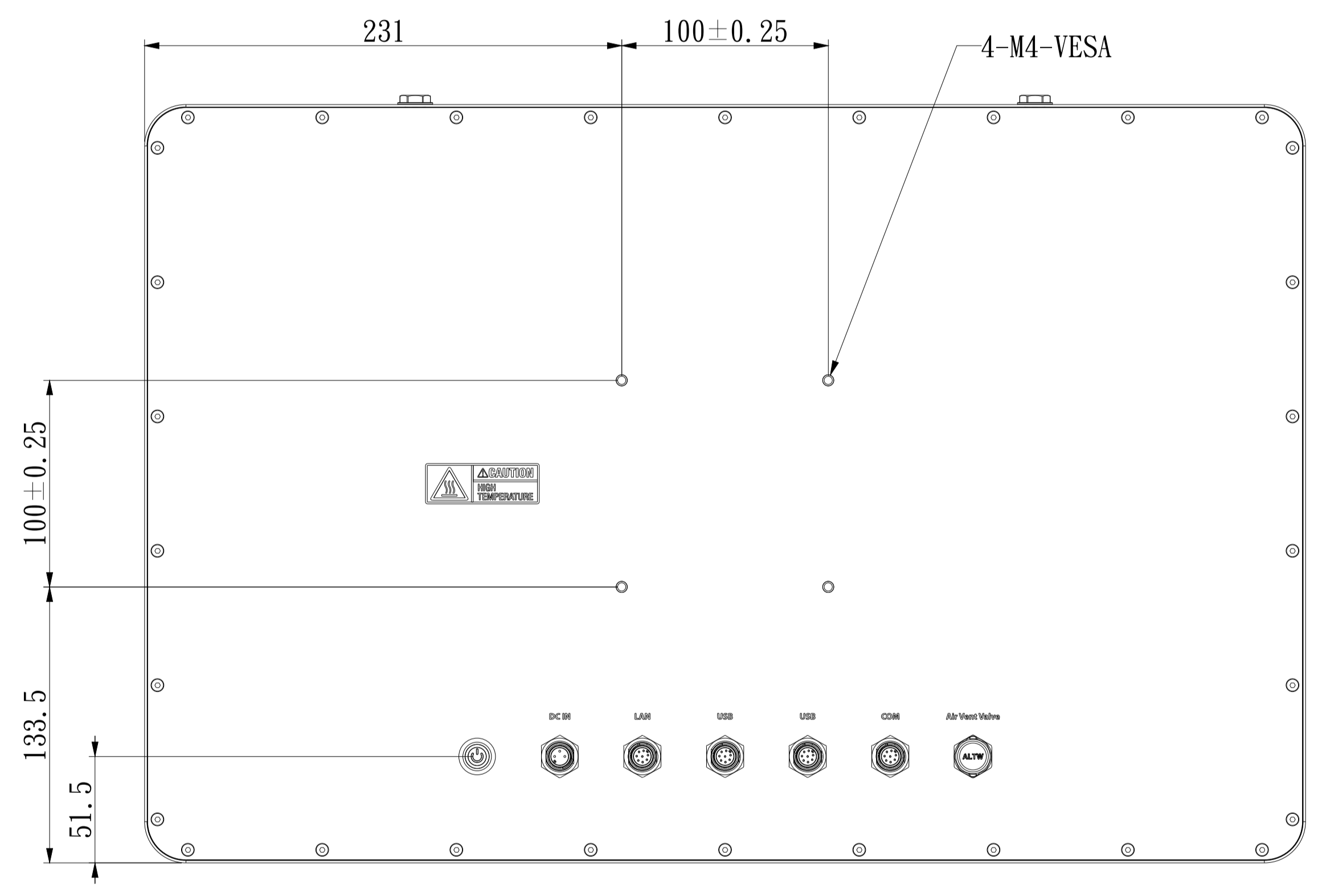
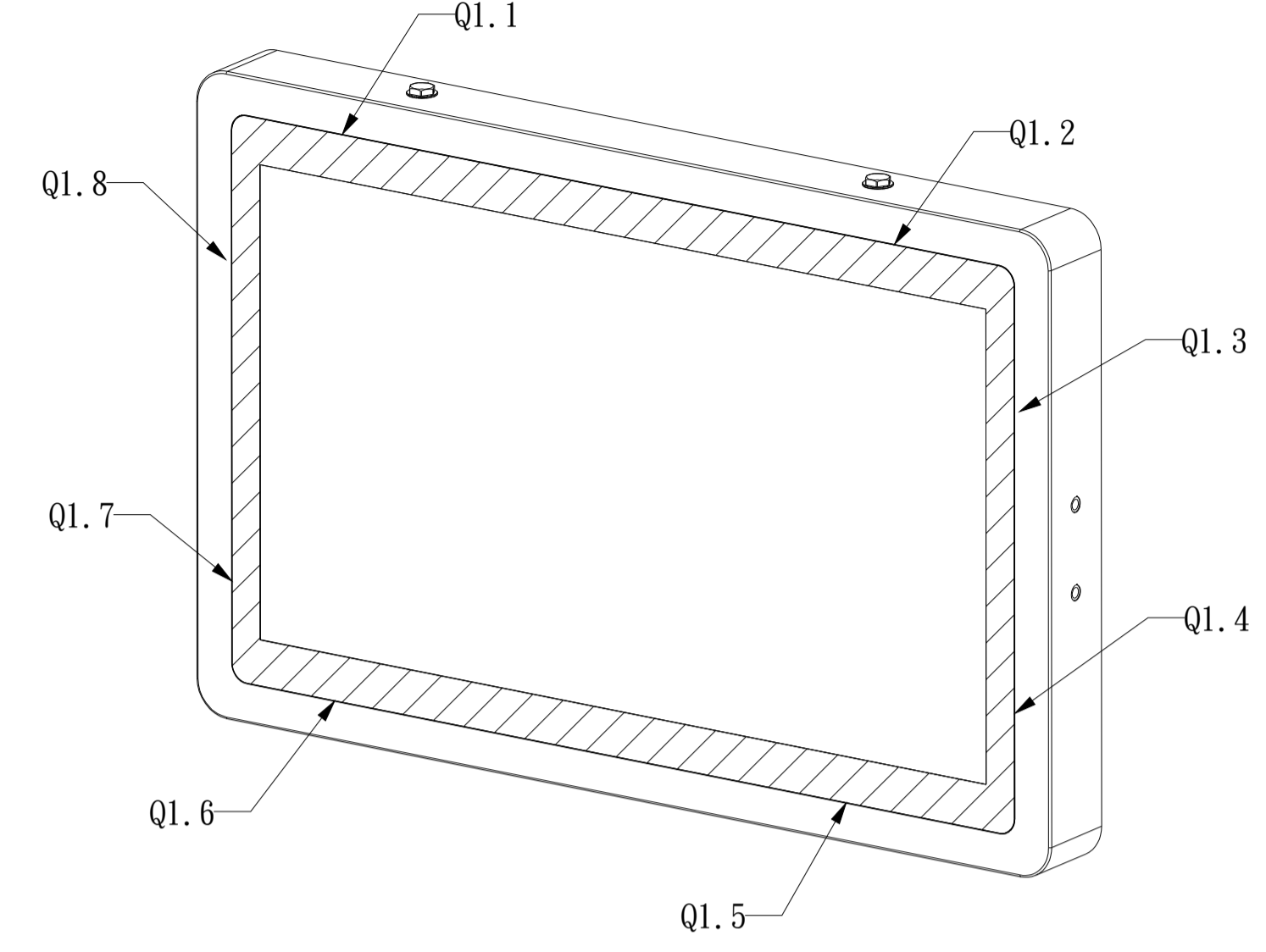
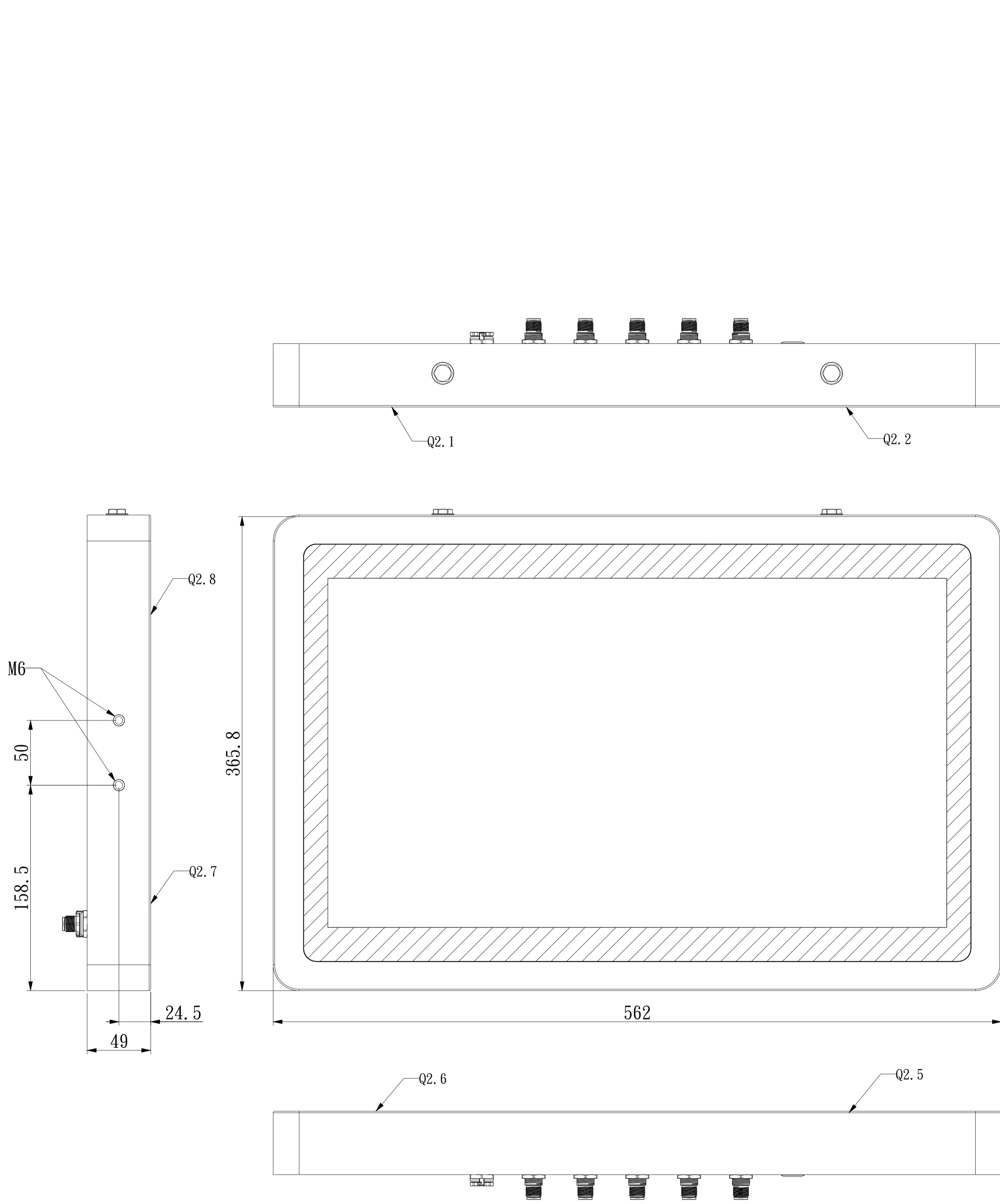

Note
 Q1: FRONT BEZEL / PCAP TOUCH GAP
 MIN 0.00mm MAX 0.9mm
 Q2: PCAP TOUCH SURFACE PROJECTION W/ FRONT BEZEL
 MIN -0.3mm MAX 0.8mm

Note:
 1. 檢驗尺寸。共 處
 2. 未標示公差，皆依圖框一般公差表檢驗
 3. 所有標示之尺寸，皆為表面處理後之尺寸
 4. 此料件為 級面

SYMBOL	A	B	MATERIAL:	PART No.					安勤科技股份有限公司 Avalite Technology Inc.	
>0	= 0.1	= 0.1	SPEC:	EMR Number	T75071-00				NAME	系統機櫃
>10	= 0.15	= 0.2	FINISH:	APPROVED	CHECKED	DESIGNED	DRAWN	REV.	A2	SHEET: 1/1
>50	= 0.25	= 0.3	UNIT:MM	Dragon Huang	Dragon Huang	Koko Chang	Koko Chang	MODEL No.	SFC-2133-B1	
>200	= 0.3	= 0.4	SCALE:	20210906	20210906	20210906	20210906	REV.	A2	
>500	= 0.5	= 0.6	ANGLE TOL. = 0.5	1:2	20210906	20210906	20210906	REV.	A2	1/1

ΔE	≤ 1.5	-1	≤ ΔL、Δa、Δb	1
----	-------	----	------------	---