

OFT-21WR2

21.5" Open Frame Tablet

Quick Reference Guide

4th Ed – 04 January 2024

Copyright Notice

Copyright © 2024 Avalue Technology Inc., ALL RIGHTS RESERVED.



Federal Communication Commission Interference Statement

THIS DEVICE COMPLIES WITH PART 15 OF THE FCC RULES. OPERATION IS SUBJECT TO THE FOLLOWING TWO CONDITIONS: (1) THIS DEVICE MAY NOT CAUSE HARMFUL INTERFERENCE AND (2) THIS DEVICE MUST ACCEPT ANY INTERFERENCE RECEIVED, INCLUDING INTERFERENCE THAT MAY CAUSE UNDESIRE OPERATION.

Note: This equipment has been tested and found to comply with the limits for a Class A digital device, pursuant to Part 15 of FCC Rules. These limits are designed to provide reasonable protection against harmful interference in a residential installation. This equipment generates, uses and can radiate radio frequency energy and, if not installed and used in accordance with the instruction, may cause harmful interference to radio communications. However, there is no guarantee that interference will not occur in a particular installation. If this equipment does cause harmful interference to radio or television reception, which can be determined by turning the equipment off and on, the user is encouraged to try to correct the interference by one or more of the following measures:

- **Reorient or relocate the receiving antenna.**
- **Increase the separation between the equipment and receiver.**
- **Connect the equipment into an outlet on a circuit different from that to which the receiver is connected.**
- **Consult the dealer or an experienced radio/TV technician for help.**

Notice:

- (1) **A Unshielded-type power cord is required in order to meet FCC emission limits and also to prevent interference to the nearby radio and television reception. It is essential that only the supplied power cord be used.**
- (2) **Use only shielded cables to connect I/O devices to this equipment.**
- (3) **Changes or modifications not expressly approved by the party responsible for compliance could void the user's authority to operate the equipment.**

FCC RF Radiation Exposure Statement

This Wireless LAN radio device has been evaluated under FCC Bulletin OET 65 and found compliant to the requirements as set forth in CFR 47 Sections 2.1091, 2.1093, and 15.247 (b) (4) addressing RF Exposure from radio frequency devices. The radiated output power of this Wireless LAN device is far below the FCC radio frequency exposure limits. Nevertheless, this device shall be used in such a manner that the potential for human contact during normal operation is minimized. When nearby persons has to be kept to ensure RF exposure compliance, in order to comply with RF exposure limits established in the ANSI C95.1 standards, the distance between the antennas and the user should not be less than 20 cm.

WARNING

“CAUTION – Use suitable mounting apparatus to avoid risk of injury.”

“CAUTION – This is a Class A product. In a domestic environment this product may cause radio interference in which case the user may be required to take adequate measures”

“CAUTION –Risk of explosion if battery is replaced by an incorrect type. Dispose of used batteries according to the instructions.”

“CAUTION - Use a power cord that matches the voltage of the power outlet, which has been approved and complies with the safety standard of your particular country.”

“WARNING – To avoid risk of electric shock, this equipment must only be connected to a supply mains with protective earth.”

Content

1. Getting Started	7
1.1 Safety Precautions	7
1.2 Packing List	7
1.3 System Specifications	8
1.4 System Overview.....	11
1.4.1 Side View	11
1.4.2 Bottom View	11
1.5 System Dimensions.....	12
1.5.1 Front and Rear side	12
1.5.2 Installing Extend Brackets.....	13
1.6 Flush Mounting Concept	14
1.7 Panel Mounting	15
1.8 Wall Mounting Concept.....	20
1.9 Wall Mounting	21
2. Hardware Configuration	28
2.1 ACP-RK3568 Overviews.....	29
2.2 ACP-RK3568 Connector list	30
2.3 Ethernet LED behavior.....	31
2.4 Evaluation Cable Kit (Optional).....	31
2.5 ACP-RK3568 Jumpers & Connectors settings.....	32
2.5.1 OTG ID select (JUSBID)	32
2.5.2 Touch button board connector (JTB1)	32
2.5.3 General purpose I/O connector (JDIO1)	33
2.5.4 RS-485 connector (JRS485).....	33
2.5.5 Camera connector (JCAM1)	34
2.5.6 A-MIC connector (JAMIC1).....	34
2.5.7 DC Power-in connector (DCIN2).....	35
2.5.8 Speaker connector (JSPK1).....	35
2.5.9 10" Touch Panel connector (J10TP)	36
2.5.10 21" Touch Panel connector (J21TP1)	36
2.5.11 Sensor connector (JSENSE).....	37
2.5.12 Debug connector (JDBG1).....	37
2.5.13 Serial port 1 connector (JCOM1)	38
2.5.14 RTC Battery connector (JRTC).....	38
2.5.15 LVDS connector (JLVDS).....	39
2.5.16 MIPI Port (JMIPI).....	40

OFT-21WR2

2.5.17	Backlight connector (JLVBL).....	41
2.5.18	7" Touch Panel connector (J7TP1).....	41

1. Getting Started

1.1 Safety Precautions

Warning!



Always completely disconnect the power cord from your chassis whenever you work with the hardware. Do not make connections while the power is on. Sensitive electronic components can be damaged by sudden power surges. Only experienced electronics personnel should open the PC chassis.

Caution!



Always ground yourself to remove any static charge before touching the CPU card. Modern electronic devices are very sensitive to static electric charges. As a safety precaution, use a grounding wrist strap at all times. Place all electronic components in a static-dissipative surface or static-shielded bag when they are not in the chassis.

1.2 Packing List

- 1 x OFT-21WR2 Open Frame Tablet
- Power cord / Power adapter (Optional)



If any of the above items is damaged or missing, contact your retailer.

1.3 System Specifications

Board Specification	
Mother Board	ACP-RK3568
CPU	RK3568_Quad-core Cortex-A55 up to 2.0GHz_ Mali-G52 GPU
Memory	2GB DDR4 on board
Power Supply	DC in
Adapter	FSP AC/DC adapter 12V/5A 90 Screw Type
Microphone	1 x AMIC interface
Speaker	1 x Speaker interface
Camera	2 x 5P USB Camera
Wireless LAN	AW-CM276NF Wireless 802.11b/g/n WLAN+BT Combo Module
Bluetooth	5.0
Operating System	Android 11, Debian 10
Expansion Card	SD card slot
Storage	
eMMC	32GB
Panel	
LCD Panel	21" 1920 x 1080 (LVDS)
Resolution	1920 x 1080
Touch Screen	HD-T215WP10-F4SA (USB interface)
Touch Controller	EETI
External I/O	
DC in Power jack	1 x Power Jack
HDMI Port	1 x HDMI
USB Port	2 x USB Type A Host
Lan Port	1 x LAN1: 10/100/1000 Lan port
Audio Port	1 x Headphone Jack for Line out
Reset button	1 x Reset
Internal I/O Connectors	
USB Camera & DMIC	JCAM1: 5 x 2P_2mm USB for Camera & DMIC
Touch	J7TP: 1 x 6P USB for touch screen
M.2 Socket	1 x M.2 Key B 3042 SATA SSD/LTE card either one
Touch Key Button	JTB1: 6 x 2P_2mm
DC-IN(wafer)	4P x 1 (12 ~ 24V), pitch 2.0mm
MIPI	JMIPI: 1 x 40P

Analog MIC	JAMIC1: 1 x 3P_2mm
Speaker	JSPK1: 1 x 4P_2mm
Sensor	JSENSE: 2 x 5P_2mm
RS232	JCOM1: 1 x 5P_2mm Uart Rs232(Tx/Rx, no RTS and CTS)
RS232 & RS485	JRS485: 5 x 2P_2mm Uart Rs232(Tx/Rx, no RTS and CTS) Uart Rs485
GPIO	JGPIO1: 2 x 10P_1mm
RTC Battery	JRTC: 1 x 2P_1.25mm
Expansion Slots	1 x Micro SD slot
Debug	JDBG 1 x 3P
Mechanical	
Power Type	12V~24V wide voltage DC input
Power Connector Type	DC jack
Dimension	515x322x44.9 (mm)
Weight	0.5 kg
Color	Metallic
Fanless	Yes
OS Support	Android 11 / Debian 10
Reliability	
EMI Test	CE FCC class A
Safety	2014/35/EU EN 62368-1: 2014+A11: 2017 (Second Edition) Low Voltage Directive
Random Vibration Operation	1. PSD: 0.00454G ² /Hz, 1.5 Grms 2. Operation mode 3. Test Frequency : 5-500Hz 4. Test Axis : X,Y and Z axis 5. 30 minutes per each axis 6. IEC 60068-2-64 Test:Fh 7. Storage : CF or SSD
Sine Vibration test (Non-operation)	1 Test Acceleration : 2G 2 Test frequency : 5~500 Hz 3 Sweep : 1 Oct/ per one minute. (logarithmic) 4 Test Axis : X,Y and Z axis 5 Test time :30 min. each axis 6 System condition : Non-Operating mode

OFT-21WR2

	7. Reference IEC 60068-2-6 Testing procedures
Package vibration test	<ol style="list-style-type: none"> 1. PSD: 0.026G²/Hz , 2.16 Grms 2. Non-operation mode 3. Test Frequency : 5-500Hz 4. Test Axis : X,Y and Z axis 5. 30 min. per each axis 6. IEC 60068-2-64 Test:Fh
Shock Test	<ol style="list-style-type: none"> 1. Wave form : Half Sine wave 2. Acceleration Rate : 10g for operation mode 3. Duration Time : 11ms 4. No. of Shock : Z axis 300 times 5. Test Axis: Z axis 6. Operation mode 7. Reference IEC 60068-2-27 Testing procedures <p>Test Eb : Bump Test</p>
Package drop test	<ol style="list-style-type: none"> 1 One corner , three edges, six faces 2 ISTA 2A, IEC-60068-2-32 Test:Ed
Operating Temperature	0°C ~ 40°C
Operating Humidity	40°C @ 95% Relative Humidity, Non-condensing
Storage Temperature	-20°C ~ 60°C



Note:

1. Specifications are subject to change without notice.
2. Due to the lack of IC material, the short-term specification only has 1 set of audio amplifier. After the material condition is stable, it will be changed back to the original specification with 2 sets of amplifiers.

1.4 System Overview

1.4.1 Side View

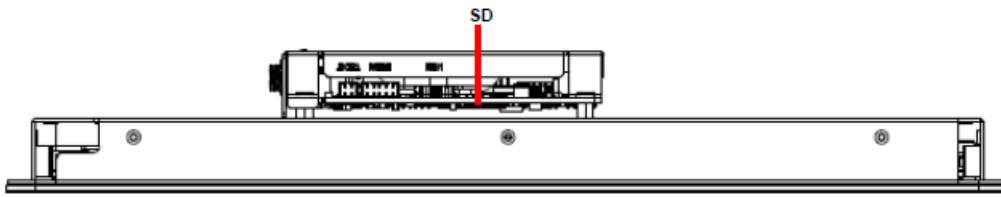

1.4.2 Bottom View

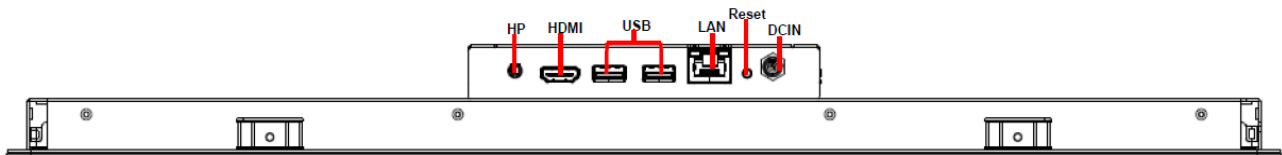

Connectors

Label	Function	Note
SD	Micro SD card slot	
HP	Audio line-out connector	
HDMI	HDMI connector	
USB	2 x USB 3.0 connector	
LAN	RJ-45 Ethernet	
Reset	Reset button	
DCIN	DC power-in connector	

1.5 System Dimensions

1.5.1 Front and Rear side

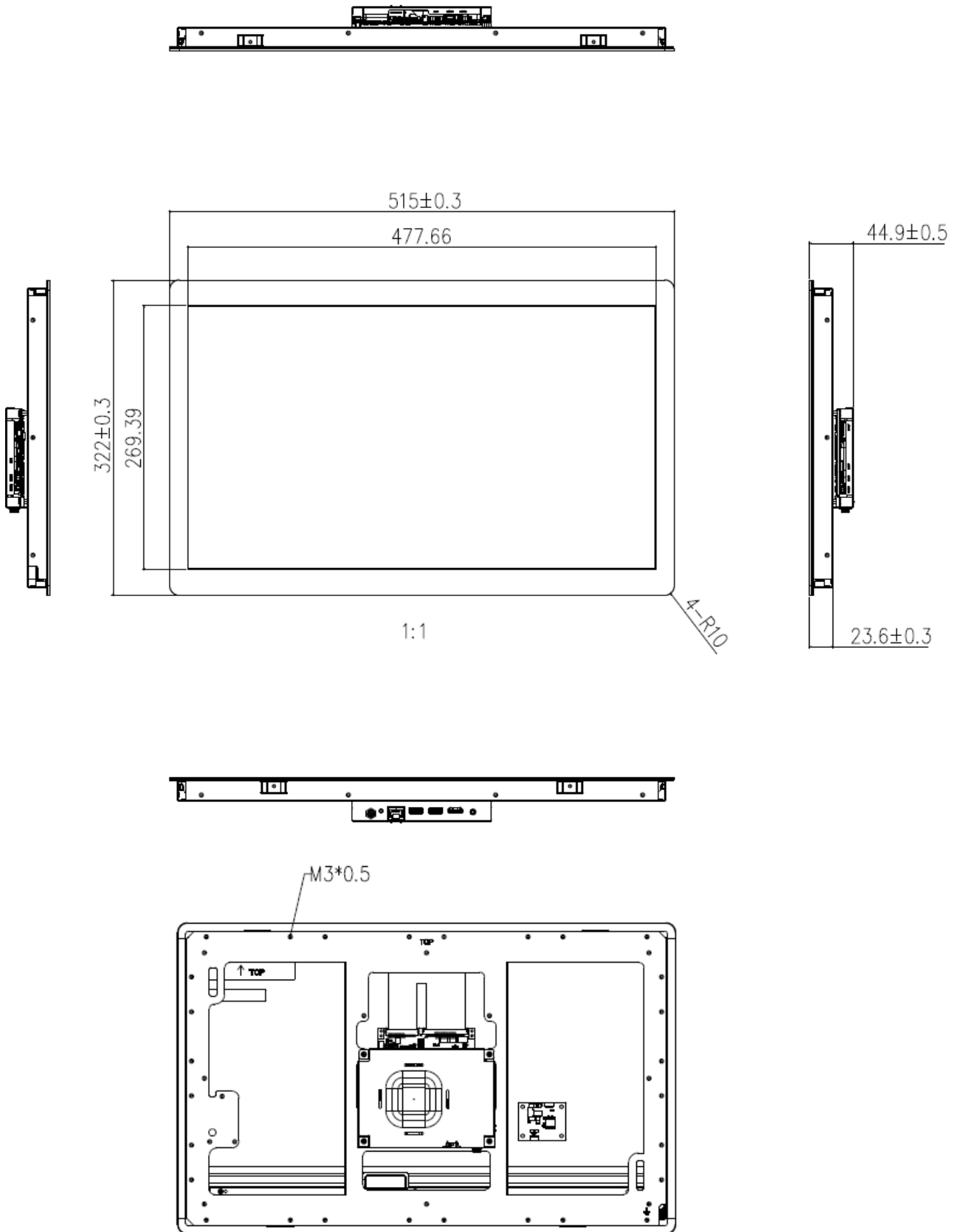

(Unit: mm)

1.5.2 Installing Extend Brackets

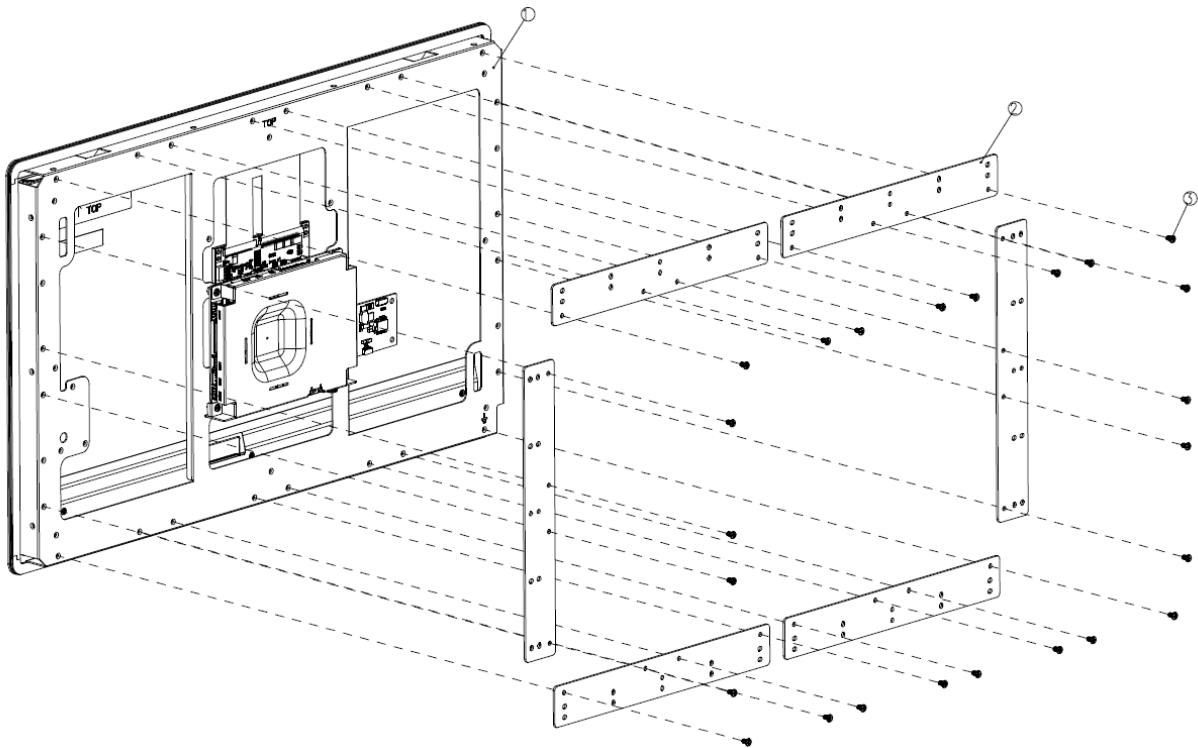

Item	Part Name	Quantity
1	OFT-21WR2	1
2	Extend bracket	6
3	Screw	24

Step1. Locate brackets on both sides, matching the holes on the monitor.

Step2. Insert and fasten 24screws on each side of the monitor to secure Mounting brackets.

Note: Brackets sold separately.

1.6 Flush Mounting Concept

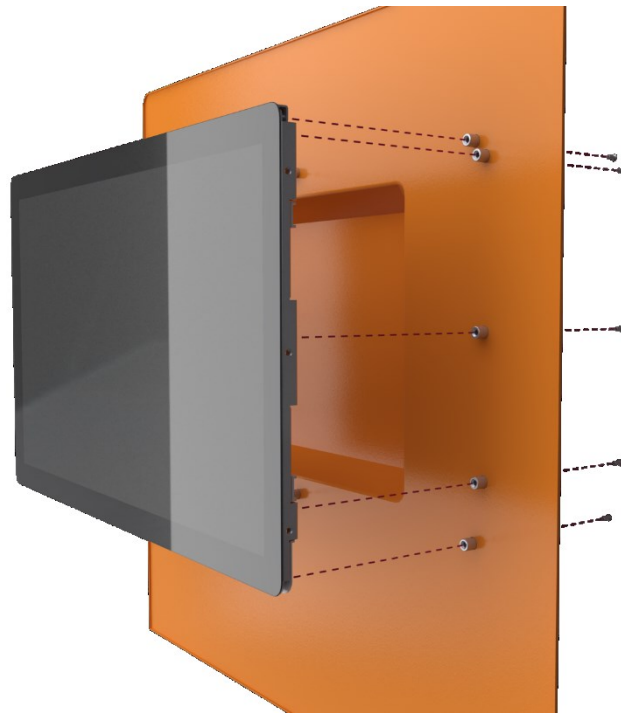

1.7 Panel Mounting

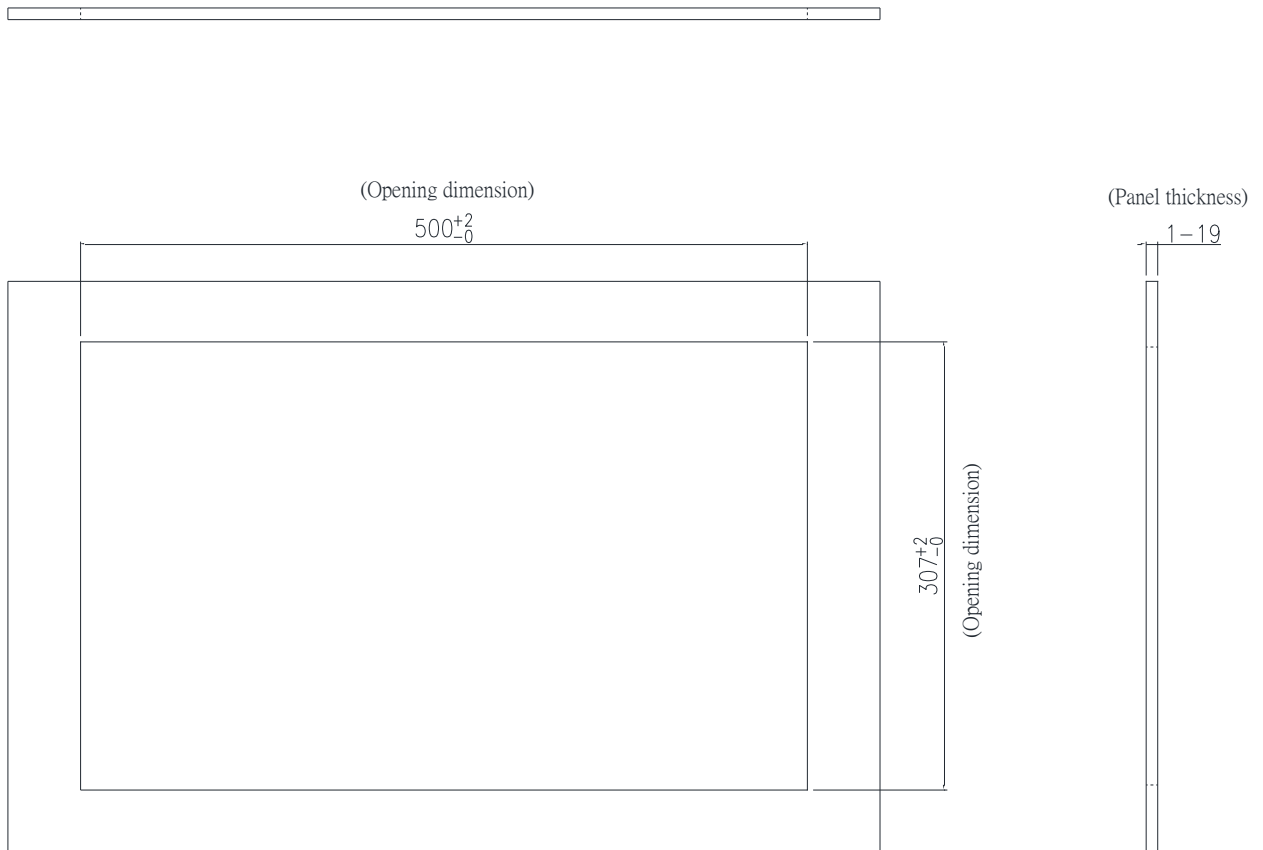

OFT-21WR2

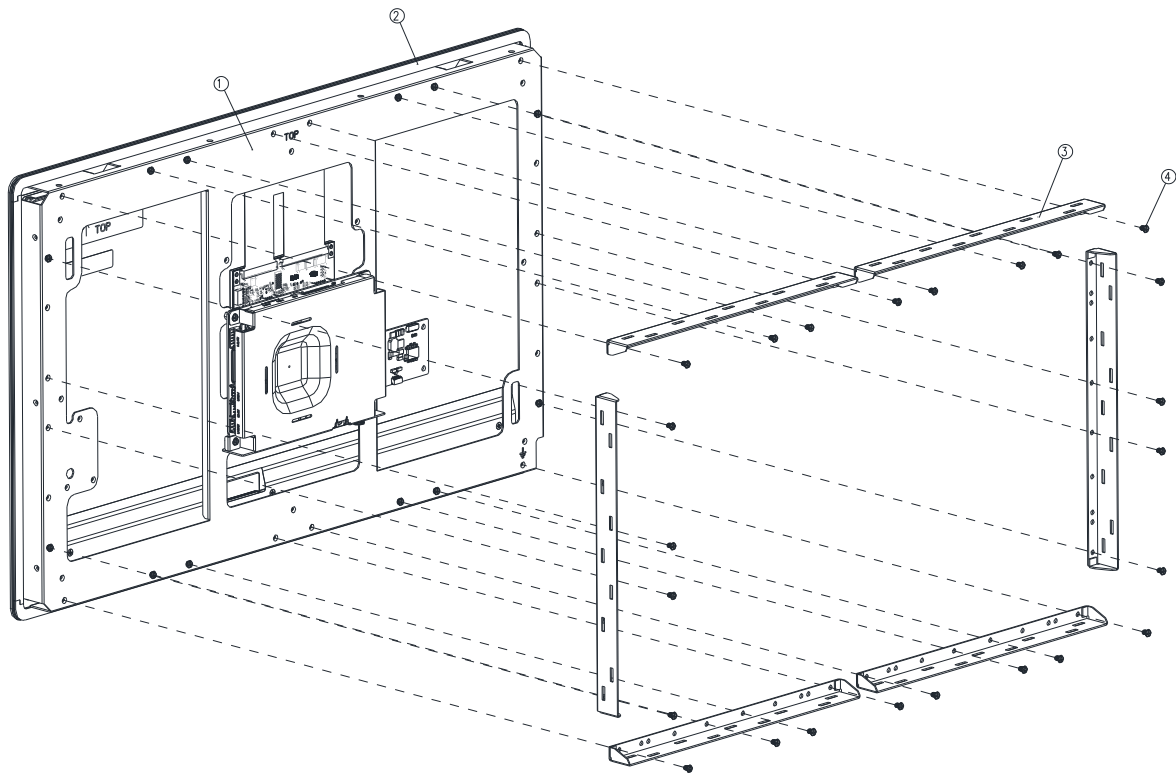

Step1. Insert and fasten 24 screws to secure Panel mount bracket.

Item	Part Name	Quantity
1	OFT-21WR2	1
2	Front sponge	1
3	Panel mount bracket	6
4	Screw	24

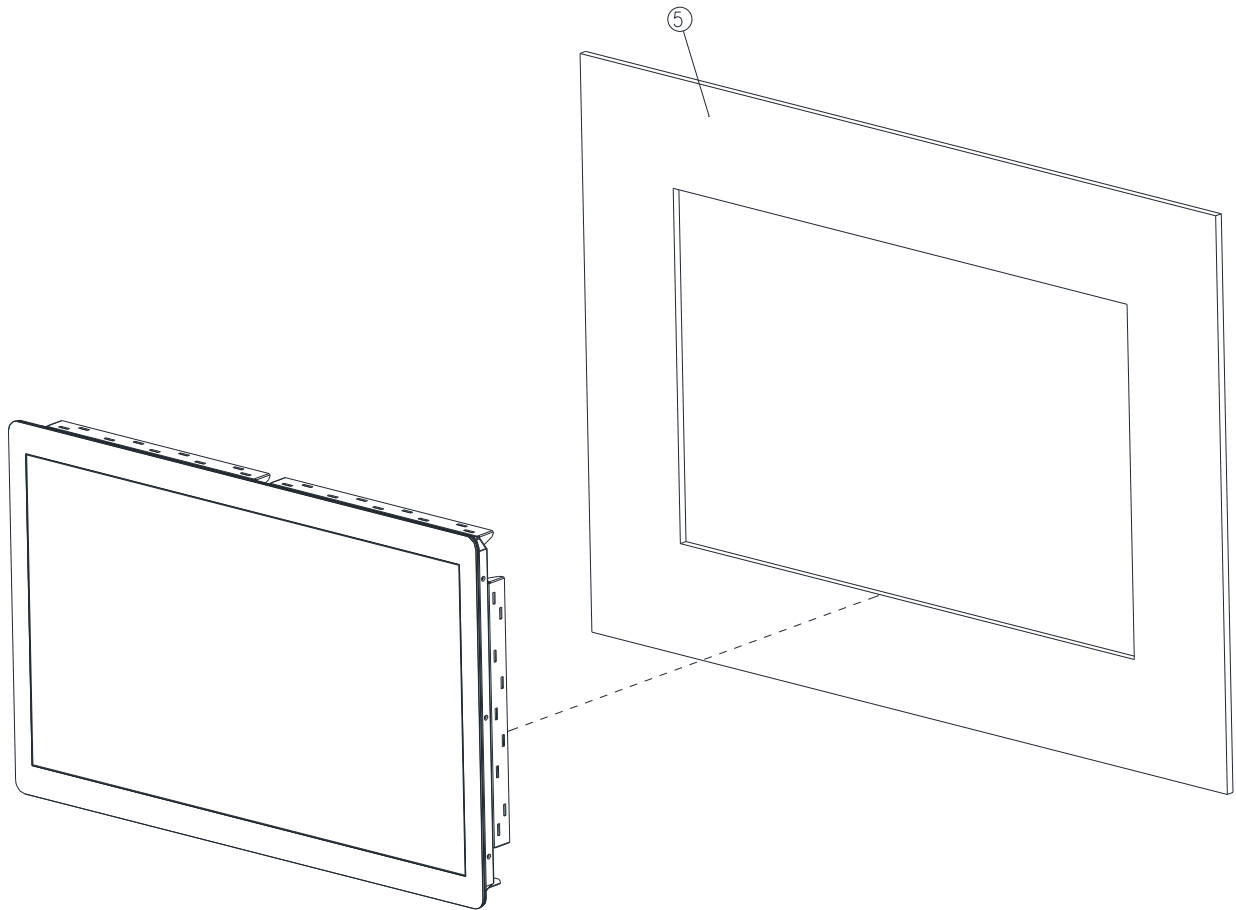

(Outside of the wall)

Step2. Insert OFT-21WR2 Open frame into the wall.

Item	Part Name	Quantity
5	Wall	1

OFT-21WR2

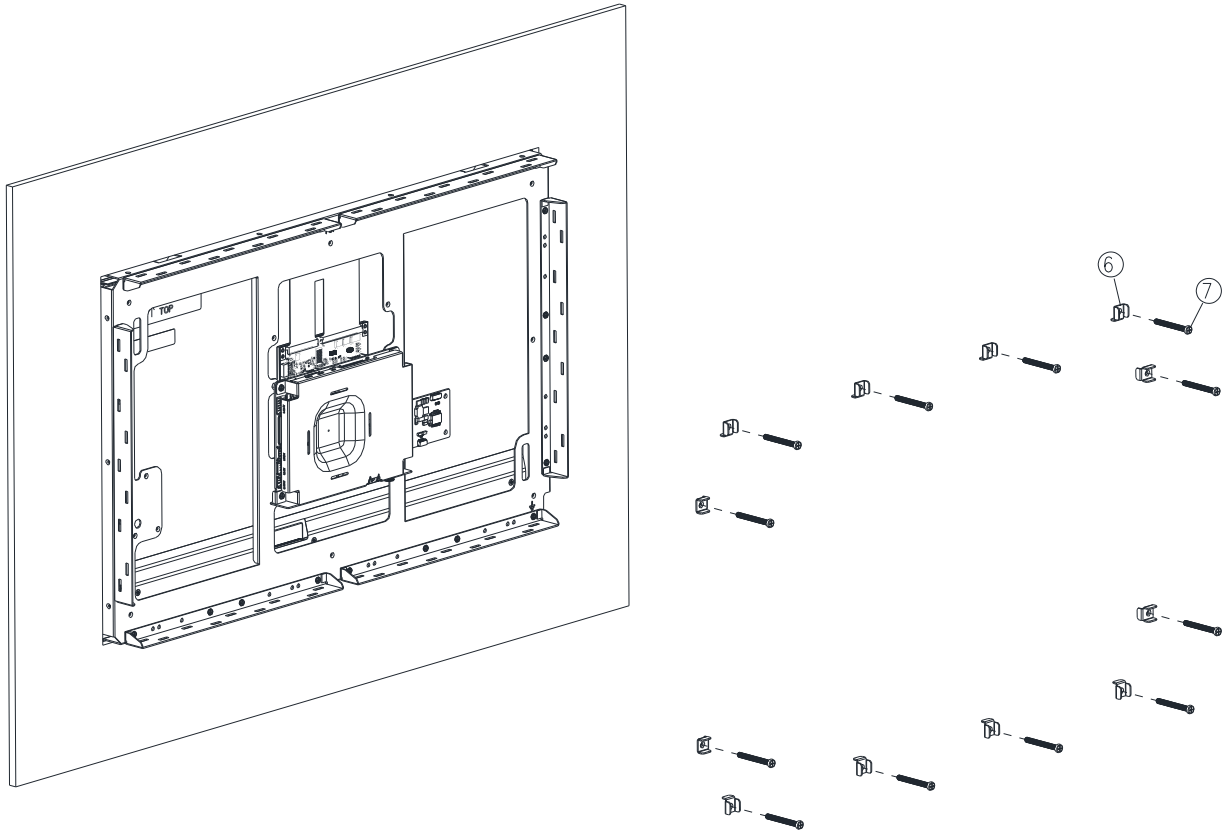

(Inside of the wall)

Step3. Fasten 12 screws to secure Panel mount kit and insert it into Panel mount Bracket.

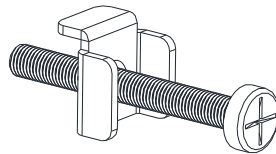

3-1

Item	Part Name	Quantity
6	Panel mount kit	12
7	Panel mount screw	12

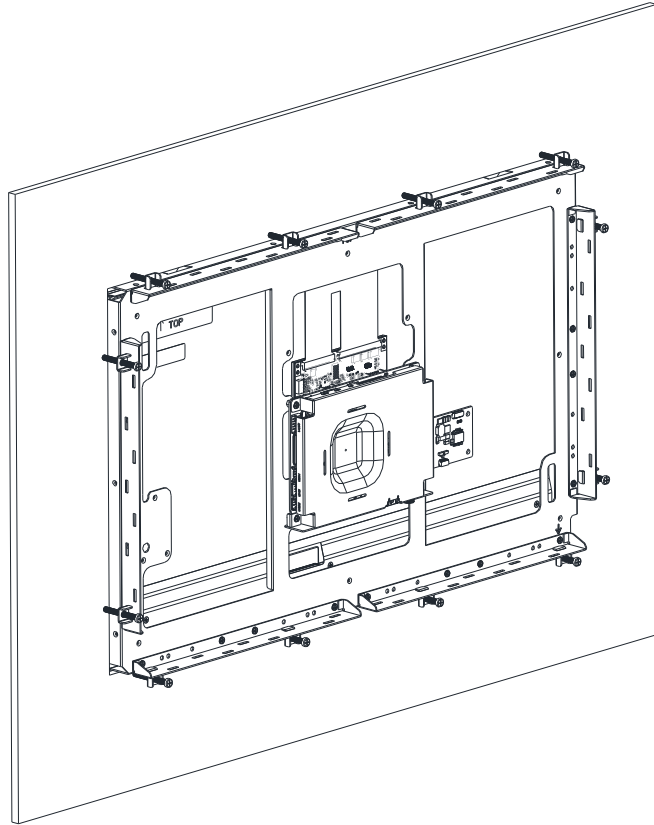

Step4. Insert and fasten 12Panel mount screws to secure the module.

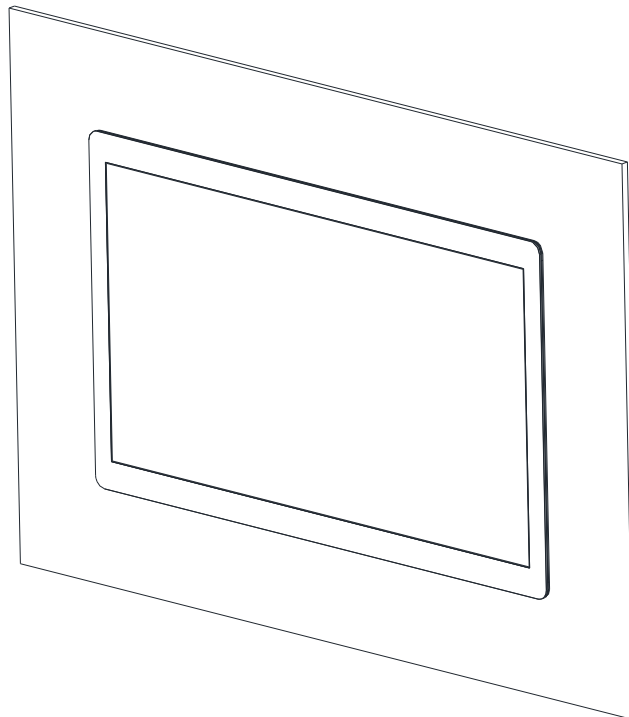

Step5. Installation completed.

1.8 Wall Mounting Concept

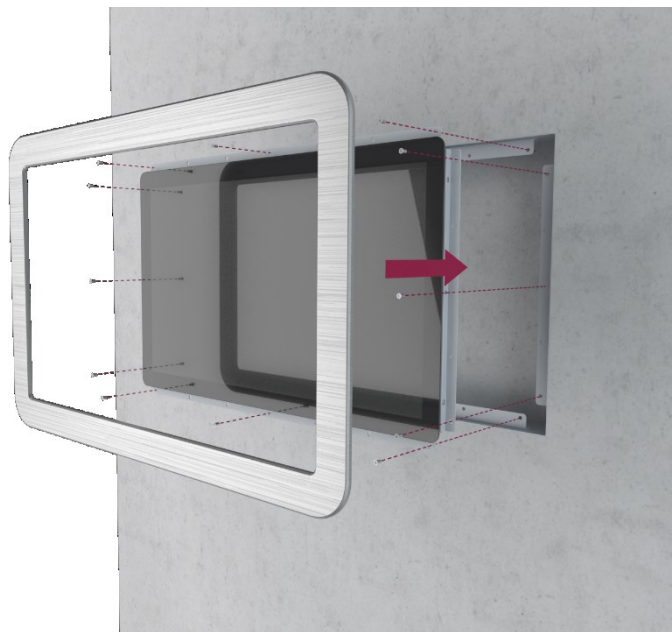
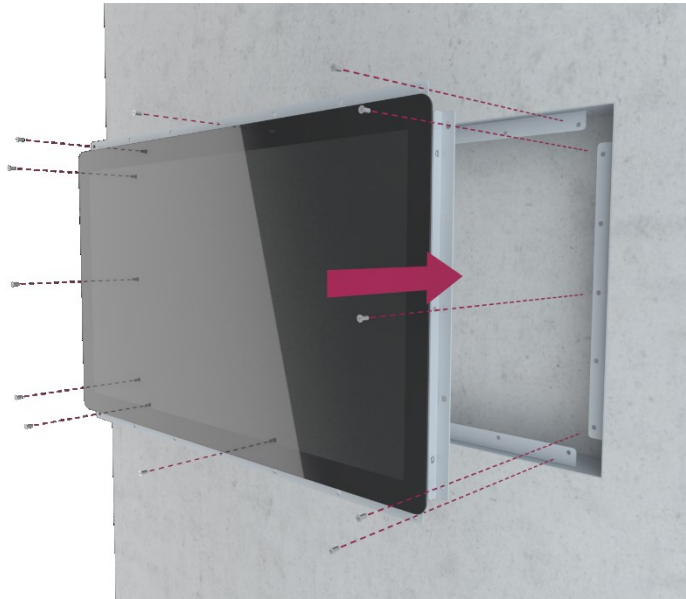

1.9 Wall Mounting

Size of the opening

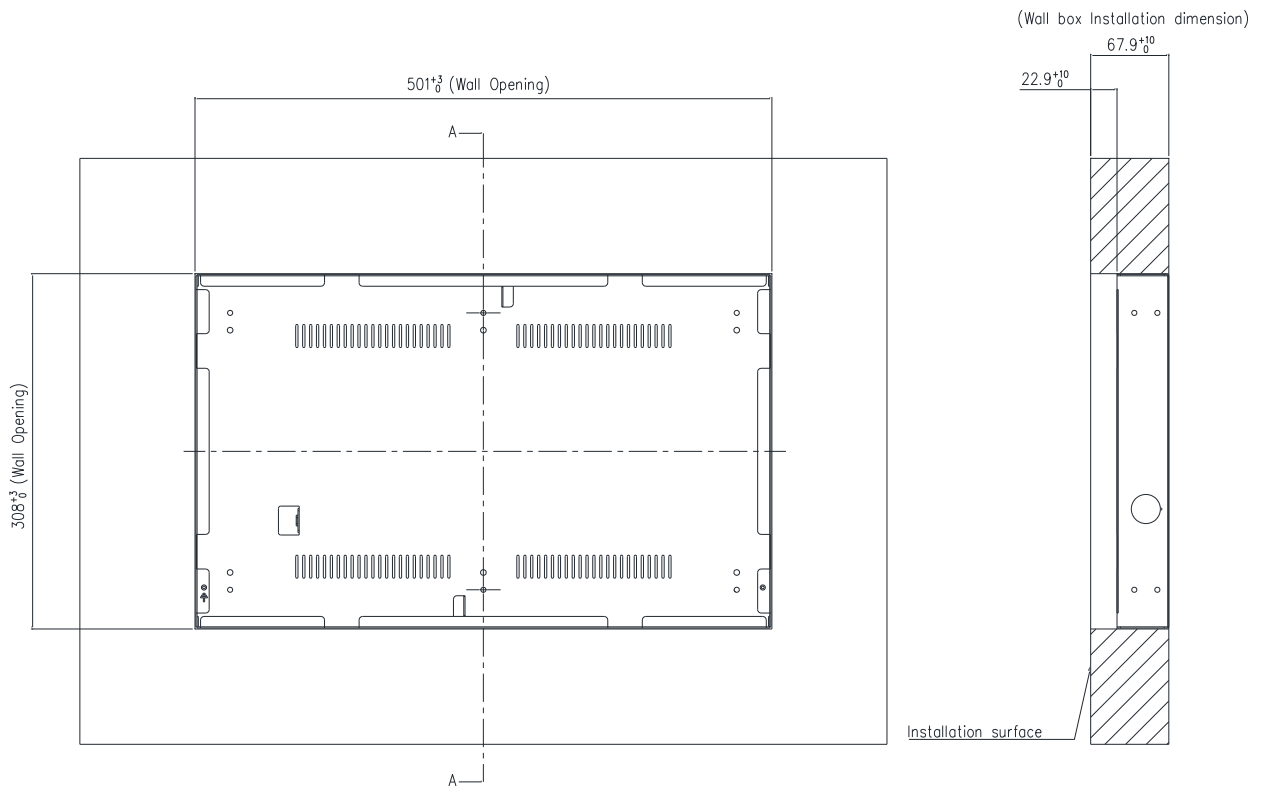

(Unit: mm)

Screw hole location

OFT-21WR2

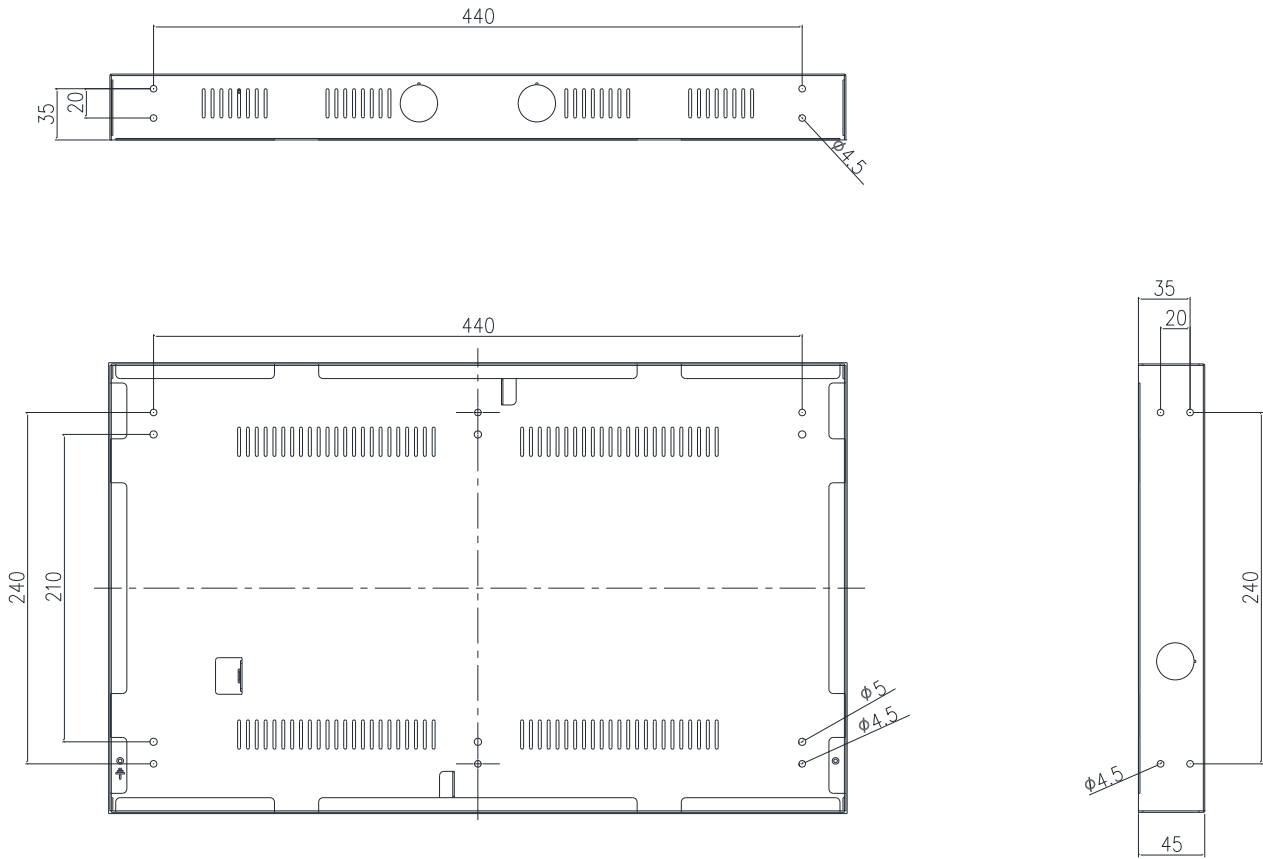

(Unit: mm)

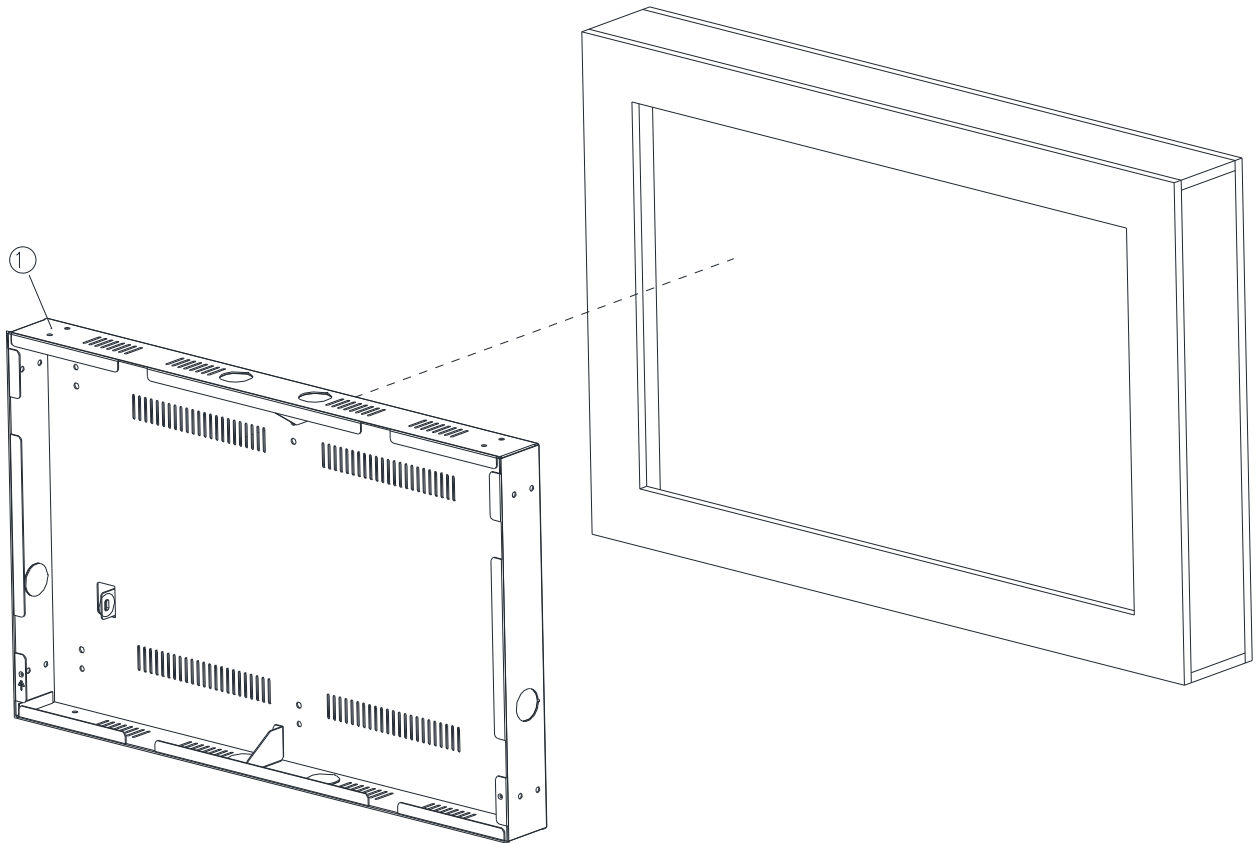

Step1. Install the 21" Wall Box and fix it on the wall, and use suitable screws to lock the wall box (the screws can be purchased according to actual needs)

1	Wall box	1
Item	Part Name	Quantity

OFT-21WR2

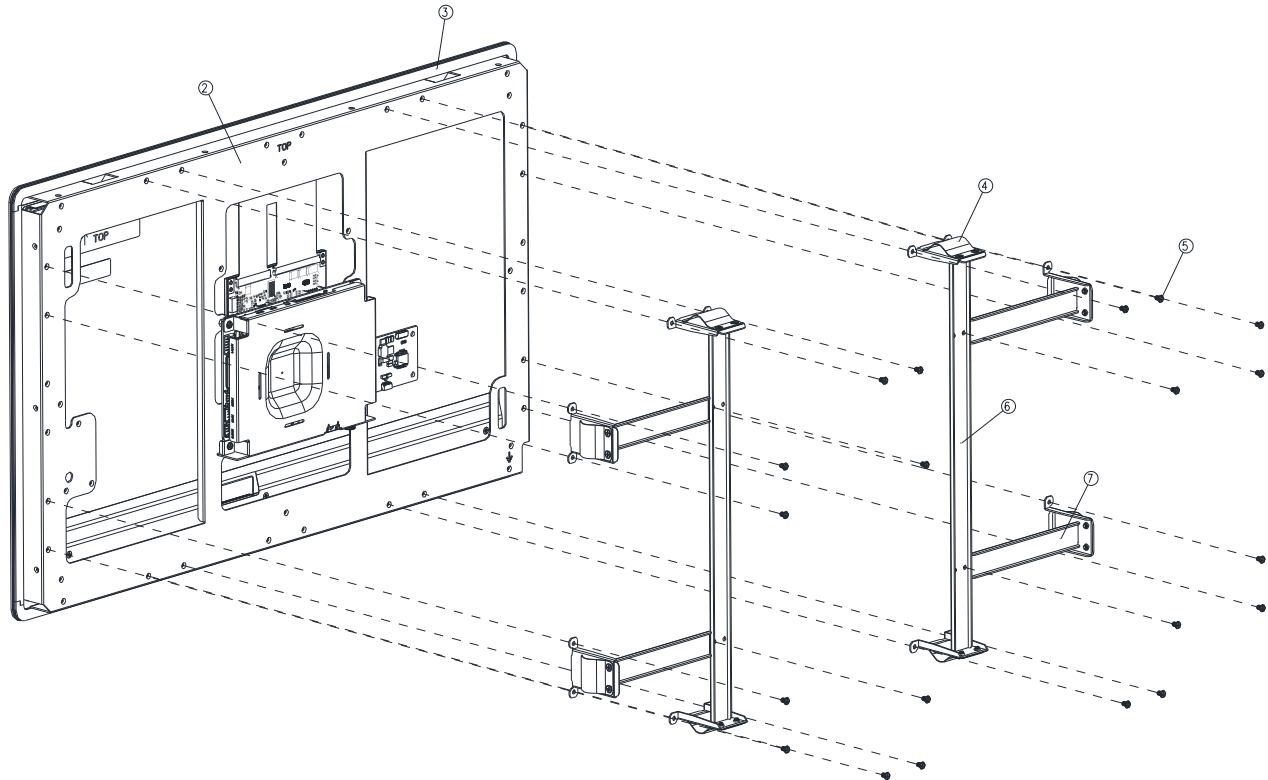

Step2-1. Paste the Sponge around the OFT-21WR2.

Step2-2. Fasten the 2 pcs Wall mount kit to the top of OFT-21WR2 with 4 screws.

Step2-3. Insert the 2 pcs Bracket-V into the locked rectangular hole of the Wall mount kit with 2 screws.

Step2-4. Insert the rectangular hole of the Wall mount kit into the Support Bracket-V and fasten 4 screws to the OFT-21WR2.

Step2-5. Fasten the 4 pcs Wall mount kit to both sides of OFT-21WR2 with 8 screws.

Step2-6. Insert the rectangular hole of the Bracket-H into the Wall mount kit and fasten 4 screws to secure Bracket-V.

7	Bracket-H	4
6	Bracket-V	2
5	Screw	20
4	Wall mount kit	8
3	Sponge	1
2	OFT-21WR2	1
Item	Part Name	Quantity

Quick Reference Guide

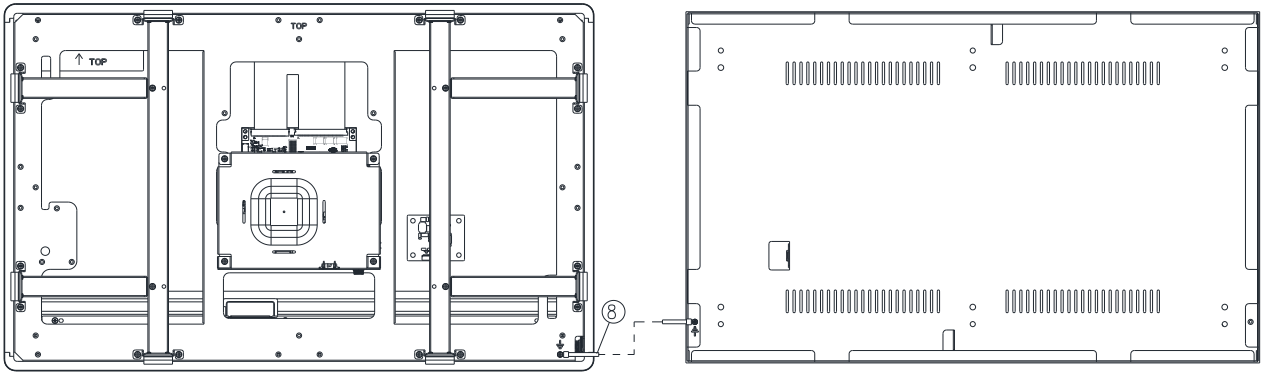

Step3. Fasten the Ground wire with 2 screws on the ground screw holes of OFT-21WR2 and Wall box.

8	Ground wire	1
Item	Part Name	Quantity

OFT-21WR2

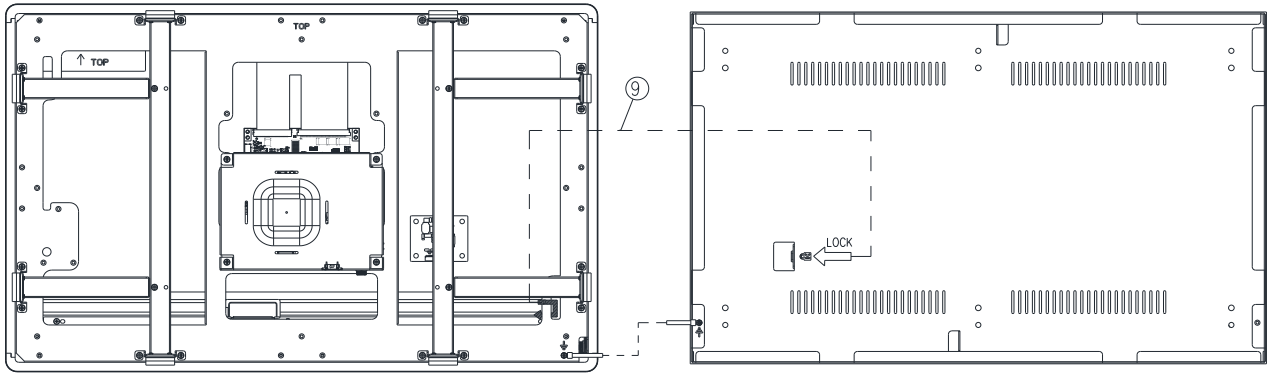

Step4. Wrap the Kensington lock (option) around the hole in the OFT-21WR2 and attach the lock to the keyhole in the Wall box.

8	Kensington lock	1
Item	Part Name	Quantity

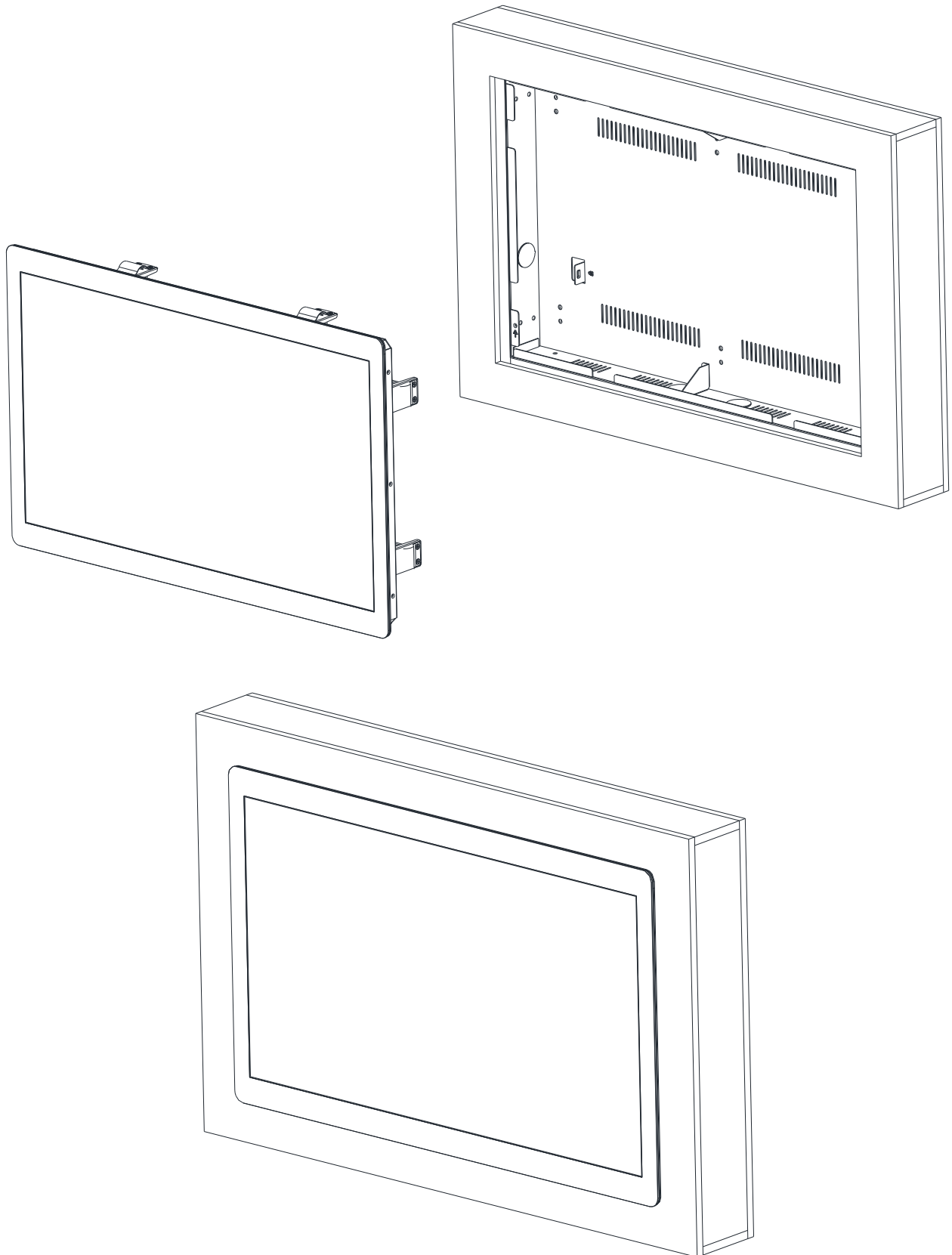

Step5. Store the Ground wire and Kensington lock in the Wall box and embed the OFT-21WR2 into the wall (Wall Box).

2. Hardware Configuration

For advanced information, please refer to:

- 1- ACP-RK3568 included in this manual.



Note: If you need more information, please visit our website:

<http://www.avalue.com.tw>

2.1 ACP-RK3568 Overviews

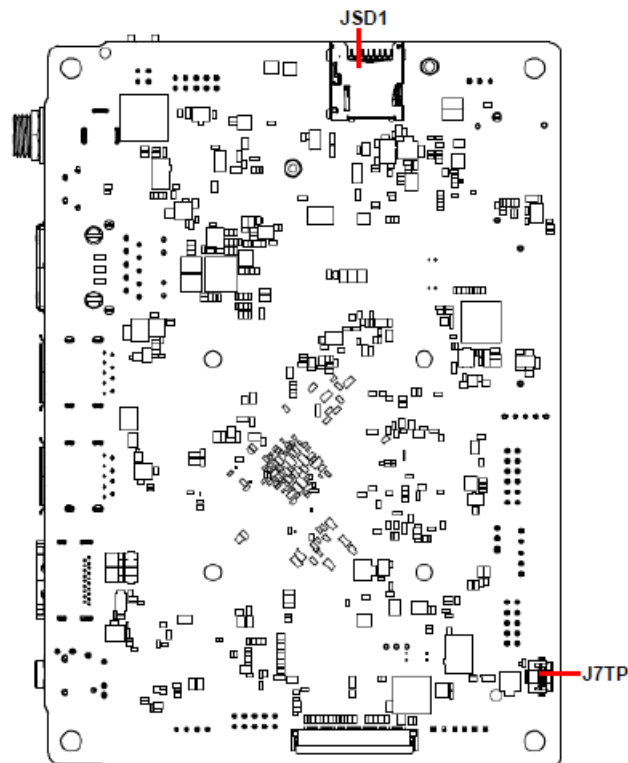
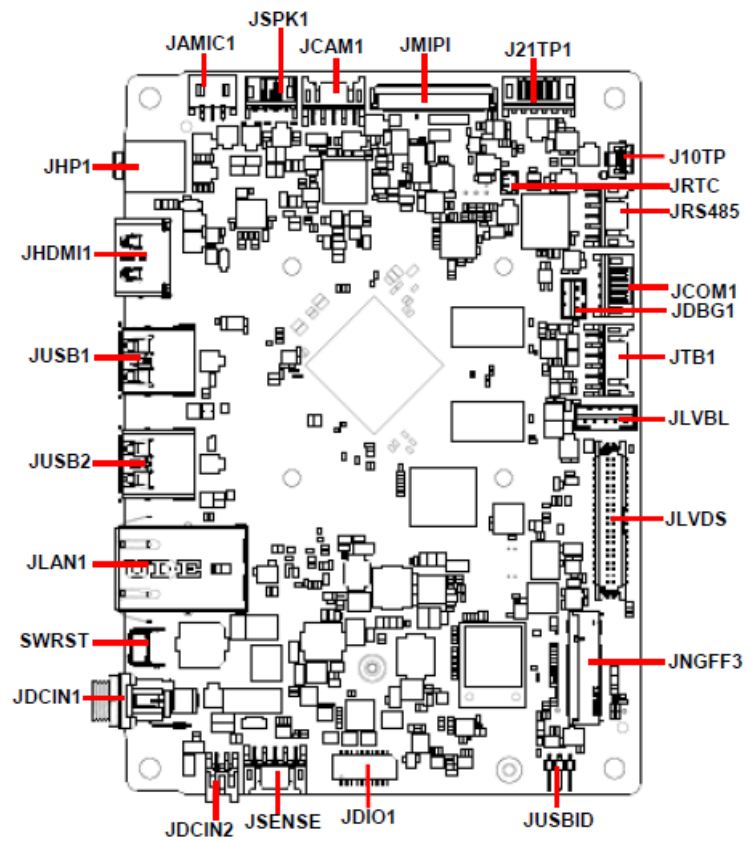

2.2 ACP-RK3568 Connector list

Jumpers

Label	Function	Note
JUSBID	OTG ID select	3 x 1 header, pitch 2.00 mm

Connectors

Label	Function	Note
JHP1	Audio line-out connector	
JHDMI1	HDMI connector	
JUSB1/2	2 x USB 3.0 connector	
JLAN1	RJ-45 Ethernet connector	
JDCIN1	DC Power-in connector	
JDCIN2	DC Power-in connector	2 x 2 wafer, pitch 2.00 mm
J21TP1	21" Touch Panel connector	6 x 1 FPC, pitch 0.50 mm (Only for OFT-21WR2)
J10TP	10" Touch Panel connector	6 x 1 FPC, pitch 0.50 mm (Only for OFT-10WR2)
JSPK1	Speaker connector	4 x 1 wafer, pitch 2.00 mm
SWRST	Reset Button	
JNGFF3	M.2 B-Key socket for WWAN	
JRTC	RTC Battery connector	2 x 1 wafer, pitch 1.25 mm
JSENSE	Sensor connector	5 x 2 wafer, pitch 2.00 mm
JDIO1	General purpose I/O connector	10 x 2 wafer, pitch 1.00 mm
JCAM1	Camera connector	5 x 2 wafer, pitch 2.00 mm
JCOM1	Serial port 1 connector	5 x 1 wafer, pitch 2.00 mm
JRS485	RS-485 connector	5 x 2 wafer, pitch 2.00 mm
JTB1	Touch button board connector	6 x 2 wafer, pitch 2.00 mm
JAMIC1	A-MIC connector	3 x 1 wafer, pitch 2.00 mm
JMIPI	MIPI Port	40 x 1 FPC, pitch 0.30 mm
JDBG1	Debug connector	3 x 1 wafer, pitch 2.00 mm
JLVDS	LVDS connector	40 x 1 FPC, pitch 0.50 mm (Only for OFT-21WR2)
JLVBL	Backlight connector	5 x 1 wafer, pitch 2.00 mm (Only for OFT-21WR2)
JSD1	Micro SD card slot	

J7TP1	7" Touch Panel connector	6 x 1 FPC, pitch 0.50 mm
-------	--------------------------	--------------------------

2.3 Ethernet LED behavior

LAN LED indicator definition

Number	Label	LED color	Indication	Meaning
1	Data Rate	Green/Orange	Off	10 Mbits/sec data rate is selected
			Green on	100 Mbits/sec data rate is selected
			Orange on	1000 Mbits/sec data rate is selected
2	Link/ACT	Yellow	Off	LAN link is not established
			Yellow on	LAN link is established
			Yellow Blinking	LAN active is occurring

2.4 Evaluation Cable Kit (Optional)

Part Number: BCC-OFT-CABLE-05R

Cable List

Cable Function	Spec. Description	Q'ty
RS-232	RS-232 Cable DB-9(M)- 5P/2.0 20cm	1
RS232/RS485	RS232/ RS-485 Cable DB-9(M)- 2x5P/2.0 23cm	1
DC In	Power cable DC JACK4P/2.0 15cm	1
USB Camera/D-MIC	USB Cable 2x5P/2.0 to 8P/0.8 10cm	1
Keypad	12P/2.0 25cm	1
GPIO	DB25(M)-1.0/20P 15cm	1
Speaker	2P 4ohm 3W 28*31*15 17cm	2

*RTC Battery

Warning: Risk of Explosion if Battery is replaced by an Incorrect Type. Dispose of Used Batteries According to the Instructions."

Attention: Risque d'explosion si la batterie est remplacée par un type incorrect. Jetez les piles usagées selon les instructions.

2.5 ACP-RK3568 Jumpers & Connectors settings

2.5.1 OTG ID select (JUSBID)

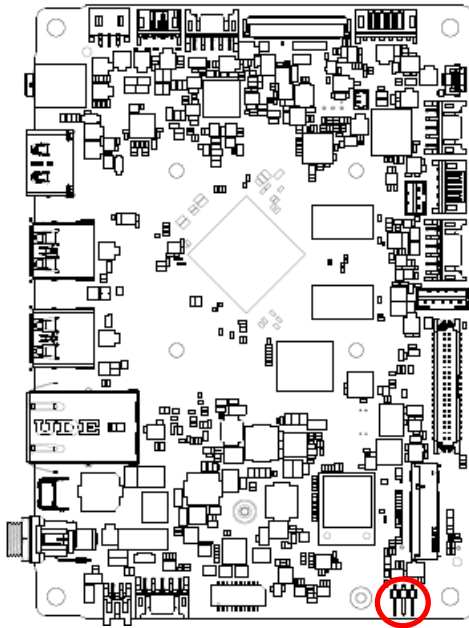

HOST*

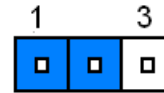

Client Mode

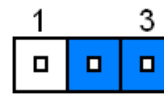

* Default

2.5.2 Touch button board connector (JTB1)

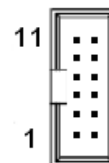
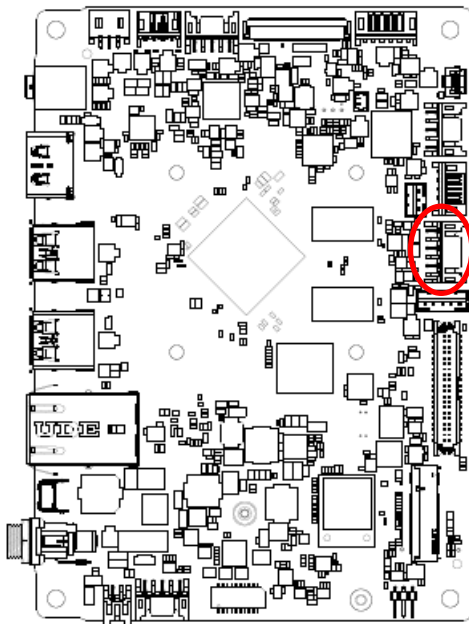

Signal	PIN	PIN	Signal
LED_GREEN_R	11	12	LED_ORANGE_R
BU_BR-_3V	9	10	BU7_3V
PWRBTN_3V	7	8	BU_BR+_3V
VOL_UP_3V	5	6	VOL_DOWN_3V
LINUX_SW	3	4	BU1_TV_3V
PWR_JTB1	1	2	GND

2.5.3 General purpose I/O connector (JDIO1)

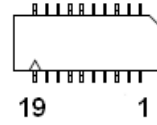
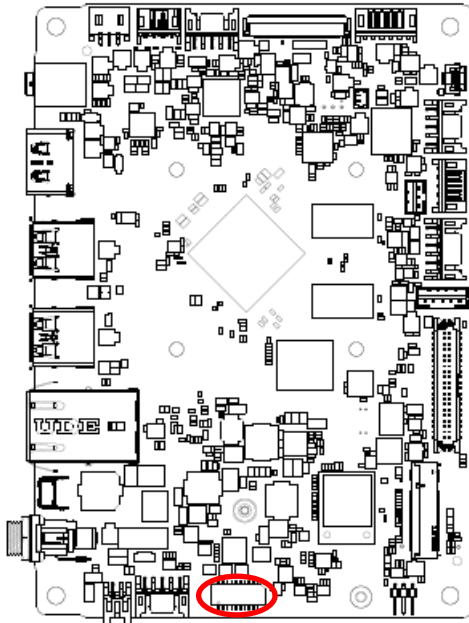

Signal	PIN	PIN	Signal
DIO_GP10	1	2	DIO_GP20
DIO_GP11	3	4	DIO_GP21
DIO_GP12	5	6	DIO_GP22
DIO_GP13	7	8	DIO_GP23
DIO_GP14	9	10	DIO_GP24
DIO_GP15	11	12	DIO_GP25
DIO_GP16	13	14	DIO_GP26
DIO_GP17	15	16	DIO_GP27
I2C_2_LV_SDA	17	18	I2C_2_LV_SCL
+V5S_DIO	19	20	GND

2.5.4 RS-485 connector (JRS485)

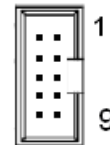
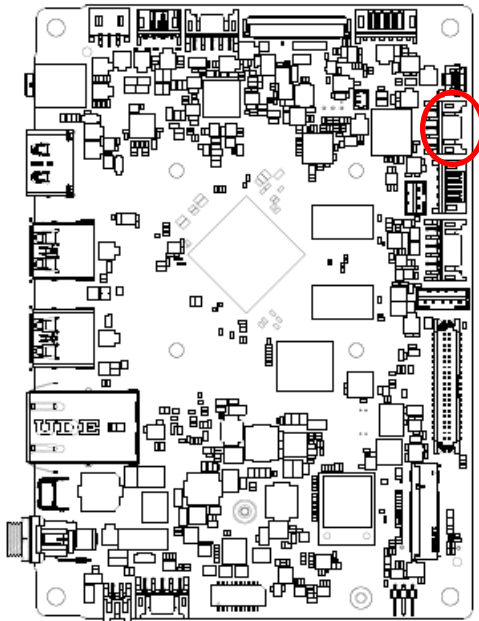

Signal	PIN	PIN	Signal
GND	2	1	GND
NC	4	3	485_TX1+
NC	6	5	485_TX1-
RS232_RX4	8	7	NC
RS232_TX4	10	9	+PWR_RS485

2.5.5 Camera connector (JCAM1)

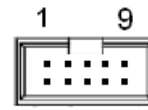
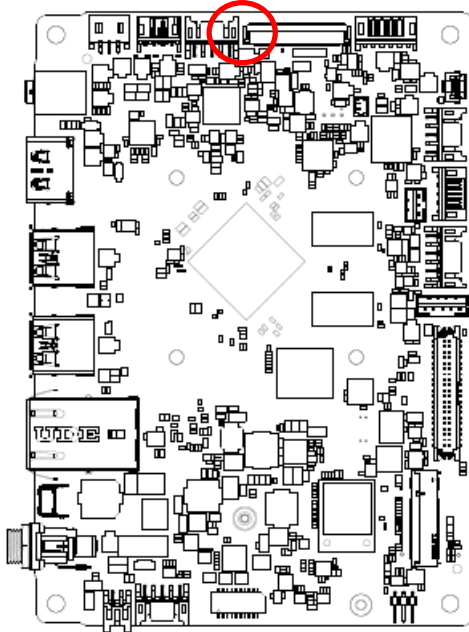

Signal	PIN	PIN	Signal
GND	1	2	GND
GND	3	4	GND
USB2_HOST3_DP_R	5	6	PDM_SDI1_DMIC_R
USB2_HOST3_DM_R	7	8	PDM_CLK1_DMIC_
+CAM_VCC (5V level)	9	10	+DMIC_VCC (3V level)

2.5.6 A-MIC connector (JAMIC1)

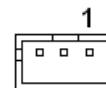
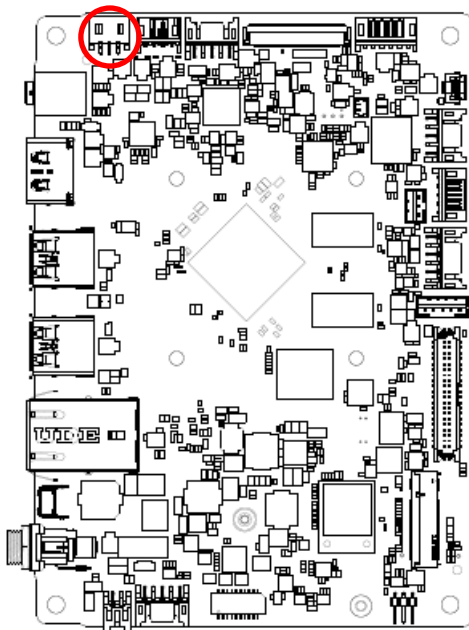

Signal	PIN
GND	1
AMIC_IN	2
MIC_JD#	3

2.5.7 DC Power-in connector (DCIN2)

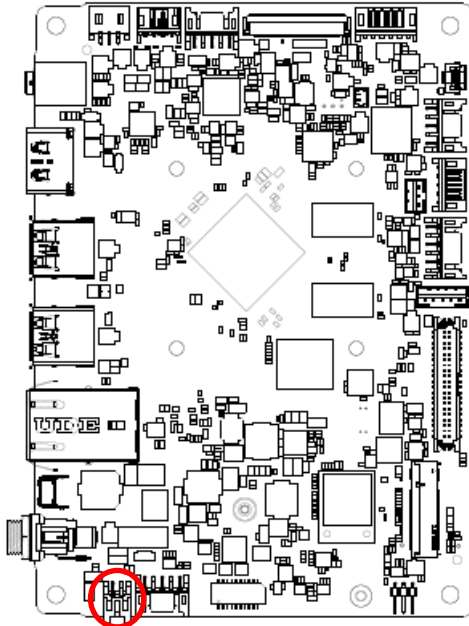

Signal	PIN	PIN	Signal
+12V_24ADPIN	1	3	+12V_24ADPIN
GND	2	4	GND

2.5.8 Speaker connector (JSPK1)

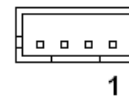
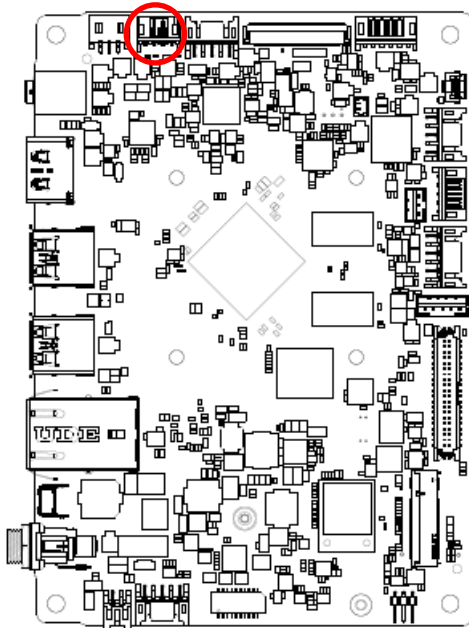

Signal	PIN
SPK_L+	1
SPK_L-	2
SPK_R+	3
SPK_R-	4

2.5.9 10” Touch Panel connector (J10TP)

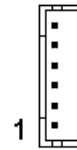
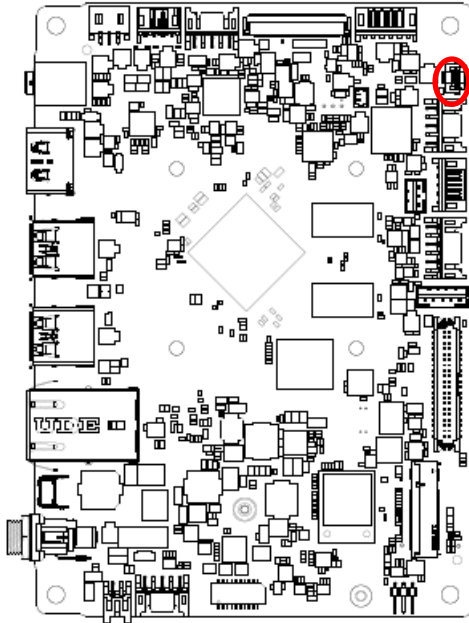

Signal	PIN
NC	6
GND	5
GND	4
USB2_10TP_DP	3
USB2_10TP_DM	2
+USB_5V_TS	1

2.5.10 21” Touch Panel connector (J21TP1)

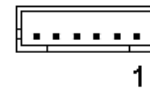
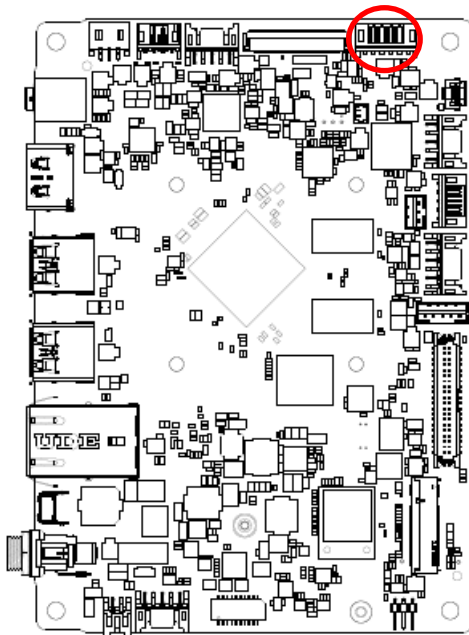

Signal	PIN
+USB_5V_TS	1
USB2_21TP_DM_R	2
USB2_21TP_DP_R	3
GND	4
GND	5
GND	6

2.5.11 Sensor connector (JSENSE)

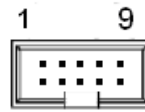
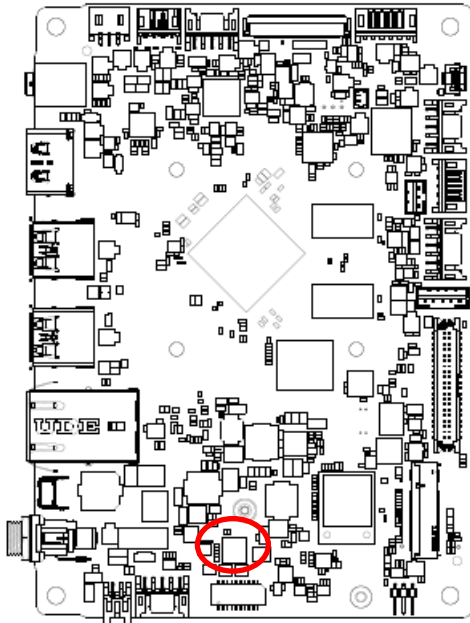

Signal	PI N	PI N	Signal
GND	1	2	GND
SENSE0_IRQ_R	3	4	SENSE2_IRQ_R
I2C3_SDA_3.3V_CON N	5	6	I2C5_SDA_3.3V_CON N
I2C3_SCL_3.3V_CONN	7	8	I2C5_SCL_3.3V_CONN
+3VS_SEN_CONN	9	10	+3VS_SEN_CONN

2.5.12 Debug connector (JDBG1)

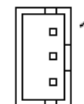
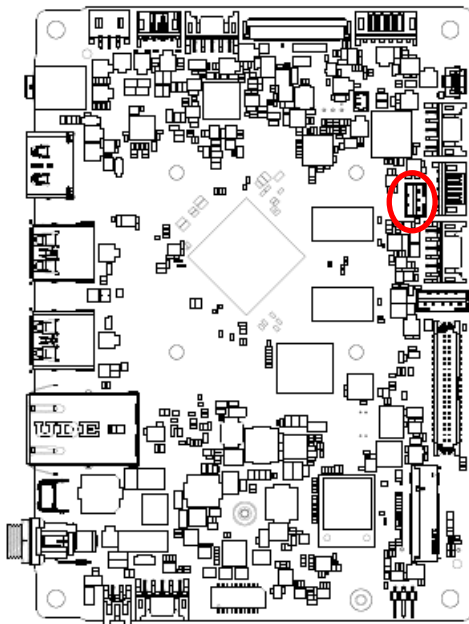

Signal	PIN
DEBUG_TX2_CON	1
DEBUG_RX2_CON	2
GND	3

2.5.13 Serial port 1 connector (JCOM1)

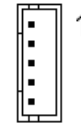
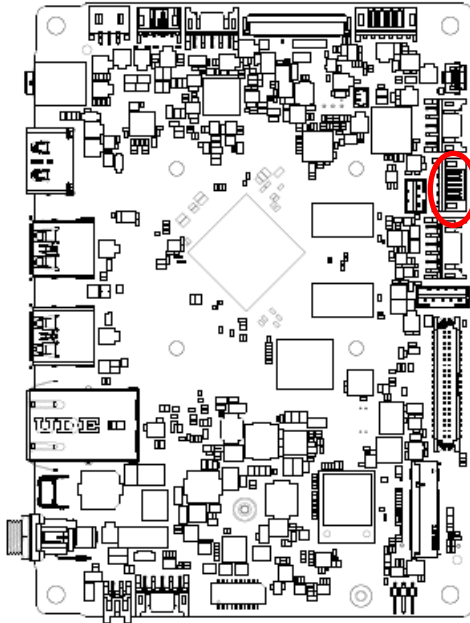

Signal	PIN
GND	1
NC	2
NC	3
RS232_RX3	4
RS232_TX3	5

2.5.14 RTC Battery connector (JRTC)

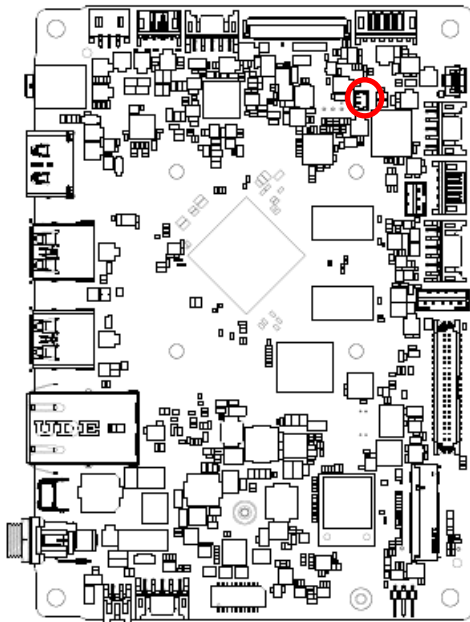

Signal	PIN
+V_BAT	1
GND	2

2.5.15 LVDS connector (JLVDS)

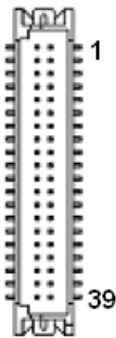
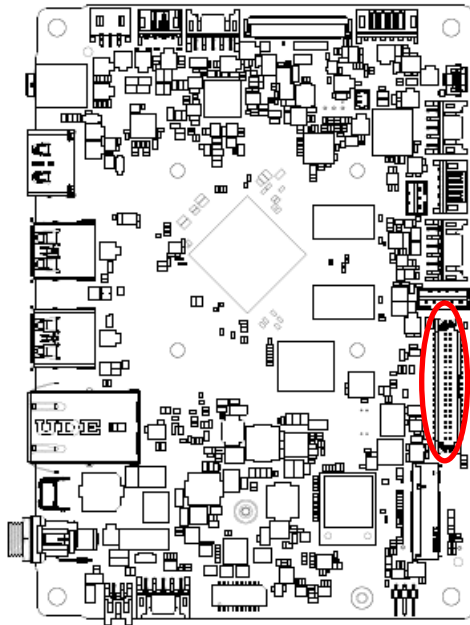

Signal	PIN	PIN	Signal
+V3.3S_LVDS	2	1	+5V_LVDS
+V3.3S_LVDS	4	3	+5V_LVDS
NC	6	5	NC
GND	8	7	GND
TXO1+	10	9	TXO0+
TXO1-	12	11	TXO0-
GND	14	13	GND
TXO3+	16	15	TXO2+
TXO3-	18	17	TXO2-
GND	20	19	GND
TXE1+	22	21	TXE0+
TXE1-	24	23	TXE0-
GND	26	25	GND
TXE3+	28	27	TXE2+
TXE3-	30	29	TXE2-
GND	32	31	GND
TXEC+	34	33	TXOC+
TXEC-	36	35	TXOC-
GND	38	37	GND
+11V2S_BL	40	39	+11V2S_BL

2.5.16 MIPI Port (JMIPI)

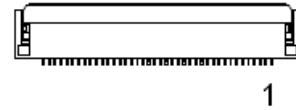
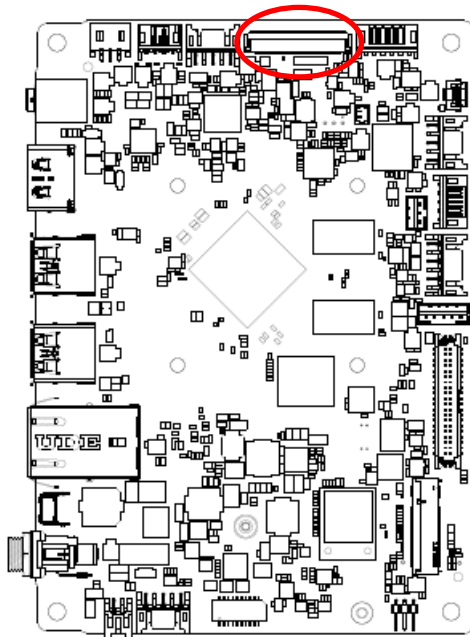

Signal	PIN
+3VS_DSI	1
+3VS_DSI	2
+3VS_DSI	3
GND	4
DSI_RESET#_3V3	5
NC	6
GND	7
MDSI_A_DN0_R	8
MDSI_A_DP0_R	9
GND	10
MDSI_A_DN1_R	11
MDSI_A_DP1_R	12
GND	13
MDSI_A_CLKN_R	14

Signal	PIN
MDSI_A_CLKP_R	15
GND	16
MDSI_A_DN2_R	17
MDSI_A_DP2_R	18
GND	19
MDSI_A_DN3_R	20
MDSI_A_DP3_R	21
GND	22
NC	23
NC	24
GND	25
NC	26
NC	27
NC	28
PANEL_LEDK	29
GND	30
PANEL_LEDK	31
PANEL_LEDK	32
NC	33
NC	34
NC	35
NC	36
NC	37
PANEL_LEDK	38
PANEL_LEDK	39
PANEL_LEDK	40

2.5.17 Backlight connector (JLVBL)

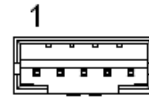
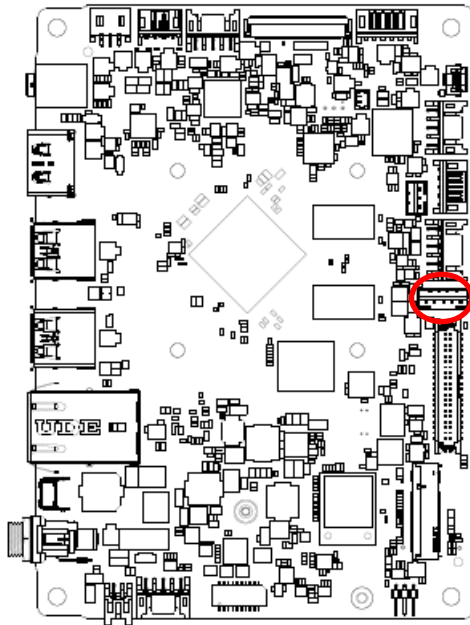

Signal	PIN
+11V2S_21BL	1
+11V2S_21BL	2
EN_BL	3
PWM_BL	4
GND	5

2.5.18 7" Touch Panel connector (J7TP1)

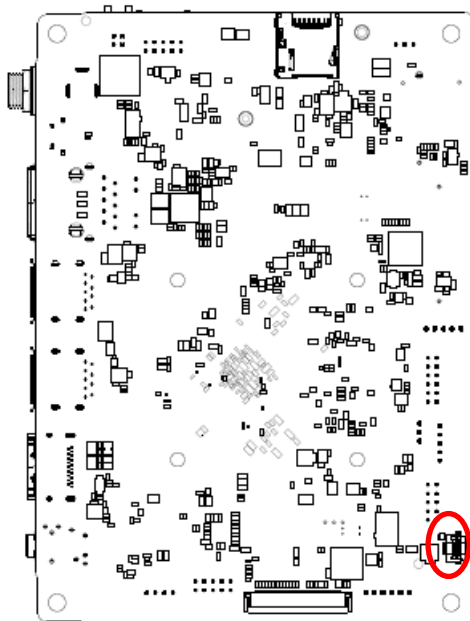

Signal	PIN
GND	6
+USB_5V_TS	5
USB2_7TP_DM	4
USB2_7TP_DP	3
NC	2
NC	1

