

APC-2138

21.5" PCAP Multi touch Full HD Panel PC w/ Core i
CPU/4USB3/2LAN/2DP/24V adapter

Quick Reference Guide

1st Ed – 27 March 2023

Copyright Notice

Copyright © 2023 Avalue Technology Inc., ALL RIGHTS RESERVED.

FCC Statement



THIS DEVICE COMPLIES WITH PART 15 FCC RULES. OPERATION IS SUBJECT TO THE FOLLOWING TWO CONDITIONS:

(1) THIS DEVICE MAY NOT CAUSE HARMFUL INTERFERENCE.

(2) THIS DEVICE MUST ACCEPT ANY INTERFERENCE RECEIVED INCLUDING INTERFERENCE THAT MAY CAUSE UNDESIRE OPERATION.

THIS EQUIPMENT HAS BEEN TESTED AND FOUND TO COMPLY WITH THE LIMITS FOR A CLASS "A" DIGITAL DEVICE, PURSUANT TO PART 15 OF THE FCC RULES.

THESE LIMITS ARE DESIGNED TO PROVIDE REASONABLE PROTECTION AGAINST HARMFUL INTERFERENCE WHEN THE EQUIPMENT IS OPERATED IN A COMMERCIAL ENVIRONMENT. THIS EQUIPMENT GENERATES, USES, AND CAN RADIATE RADIO FREQUENCY ENERGY AND, IF NOT INSTALLED AND USED IN ACCORDANCE WITH THE INSTRUCTION MANUAL, MAY CAUSE HARMFUL INTERFERENCE TO RADIO COMMUNICATIONS.

OPERATION OF THIS EQUIPMENT IN A RESIDENTIAL AREA IS LIKELY TO CAUSE HARMFUL INTERFERENCE IN WHICH CASE THE USER WILL BE REQUIRED TO CORRECT THE INTERFERENCE AT HIS OWN EXPENSE.

A Message to the Customer

Avalue Customer Services

Each and every Avalue's product is built to the most exacting specifications to ensure reliable performance in the harsh and demanding conditions typical of industrial environments. Whether your new Avalue device is destined for the laboratory or the factory floor, you can be assured that your product will provide the reliability and ease of operation for which the name Avalue has come to be known.

Your satisfaction is our primary concern. Here is a guide to Avalue's customer services. To ensure you get the full benefit of our services, please follow the instructions below carefully.

Technical Support

We want you to get the maximum performance from your products. So if you run into technical difficulties, we are here to help. For the most frequently asked questions, you can easily find answers in your product documentation. These answers are normally a lot more detailed than the ones we can give over the phone. So please consult the user's manual first.

To receive the latest version of the user's manual; please visit our Web site at:

<http://www.avalue.com.tw/>

Content

1.	Getting Started	6
1.1	Safety Precautions	6
1.2	Packing List.....	6
1.3	System Specifications	7
1.4	System Overview	10
1.4.1	Rear View	10
1.5	System Dimensions	11
2.	Hardware Configuration	12
2.1	Storage Installation	13
2.2	EMX-TGLC Overview.....	14
2.3	EMX-TGLC Jumper and Connector List.....	15
2.4	EMX-TGLC Jumpers & Connectors settings	17
2.4.1	Serial port 1/2 pin9 signal select (JRI1/JRI2)	17
2.4.2	LVDS Back Light power selection (JSBKL1).....	17
2.4.3	AT/ATX Power Mode Select (JSATX1)	18
2.4.4	M2KB1 Voltage setting (JP1)	18
2.4.5	Clear CMOS (JBAT1)	19
2.4.6	LCD Inverter connector (JBKL1)	19
2.4.7	LCD Inverter connector (JBKL2)	20
2.4.8	LVDS connector (LVDS1).....	20
2.4.9	eDP_Panel connector (EDP1).....	21
2.4.10	General purpose I/O connector (DIO1)	21
2.4.11	Serial port1 connector (JCOM1).....	22
2.4.12	Serial port2 connector (JCOM2).....	22
2.4.13	Serial port 3/4/5/6 connector (JCOM3/4/5/6).....	23
2.4.14	Serial Port 1/2 RS485/422 Mode connector (JRS485_1/2)	23
2.4.15	SATA Power connector 1 (SPWR1).....	24
2.4.16	Power connector (PWR1).....	24
2.4.17	USB connector 3 (JUSB3).....	25
2.4.18	USB connector 4 (JUSB4).....	25
2.4.19	Speaker connector (SPK1).....	26
2.4.20	SPI connector (JSPI1)	26
2.4.21	Battery connector (BT1)	27
2.4.22	Audio connector (JFAUD1).....	27

APC-2138

2.4.23	EC Debug (JEC_SPI)	28
2.4.24	Miscellaneous setting connector 1 (JFPT1)	28
2.4.25	Miscellaneous setting connector 2 (FPT2)	29
2.4.26	LPC connector (JLPC1).....	29
2.4.27	CPU fan connector (CPU_FAN1)	30
2.4.28	USIM connector (USIM2)	30
3	BIOS Setup	31
3.1	Introduction	32
3.2	Starting Setup	32
3.3	Using Setup	33
3.4	Getting Help	34
3.5	In Case of Problems.....	34
3.6	BIOS setup.....	35
3.6.1	Main Menu	35
3.6.1.1	System Language.....	36
3.6.1.2	System Date	36
3.6.1.3	System Time.....	36
3.6.2	Advanced Menu.....	36
3.6.2.1	Connectivity Configuration	37
3.6.2.2	CPU Configuration	37
3.6.2.3	Power & Performance	38
3.6.2.3.1	CPU - Power Management Control	38
3.6.2.4	PCH-FW Configuration.....	39
3.6.2.4.1	Firmware Update Configuration	39
3.6.2.5	Trusted Computing.....	40
3.6.2.6	ACPI Settings	40
3.6.2.7	EC 8528 H/W monitor	41
3.6.2.8	S5 RTC Wake Settings	41
3.6.2.9	USB Configuration.....	42
3.6.2.10	Network Stack Configuration	43
3.6.2.11	NVMe Configuration.....	43
3.6.3	Chipset.....	44
3.6.3.1	System Agent (SA) Configuration	44
3.6.3.1.1	Memory Configuration.....	45
3.6.3.1.2	Graphics Configuration	45
3.6.3.1.3	VMD Configuration.....	46
3.6.3.2	PCH-IO Configuration.....	46
3.6.3.2.1	PCI Express Configuration.....	47
3.6.3.2.1.1	PCI Express Root Port 5(LAN2-I225/I226)	47
3.6.3.2.1.2	PCI Express Root Port 6(M.2 KeyE).....	48

3.6.3.2.1.3	PCI Express Root Port 8(M.2 KeyB).....	49
3.6.3.2.2	SATA And RST Configuration	50
3.6.3.2.3	HD Audio Configuration	51
3.6.3.2.4	Board & Panel Configuration	51
3.6.4	Security	53
3.6.4.1	Secure Boot menu.....	53
3.6.5	Security	54
3.6.6	Save and exit	55
3.6.6.1	Save Changes and Reset	55
3.6.6.2	Discard Changes and Reset	55
3.6.6.3	Restore Defaults.....	56
3.6.6.4	Launch EFI Shell from filesystem device	56
4.	Drivers Installation.....	57
4.1	Install Chipset Driver	58
4.2	Install VGA Driver.....	59
4.3	Install Serial IO Driver	60
4.4	Install ME Driver	61
4.5	Install Audio Driver (For Realtek ALC897 and ALC888S HD Audio).....	62
4.6	Realtek Audio Console.....	63
4.7	Install LAN Driver	64
4.8	Install RST for RAID Driver	65

1. Getting Started

1.1 Safety Precautions

Warning!



Always completely disconnect the power cord from your chassis whenever you work with the hardware. Do not make connections while the power is on. Sensitive electronic components can be damaged by sudden power surges. Only experienced electronics personnel should open the PC chassis.

Caution!



Always ground yourself to remove any static charge before touching the CPU card. Modern electronic devices are very sensitive to static electric charges. As a safety precaution, use a grounding wrist strap at all times. Place all electronic components in a static-dissipative surface or static-shielded bag when they are not in the chassis.

1.2 Packing List

- 1 x APC-2138 Panel PC
- 1 x Power adapter



If any of the above items is damaged or missing, contact your retailer.

1.3 System Specifications

Component	
Mother Board	EMX-TGLC
CPU	Onboard Intel® 11th gen Core™ i7-1165G7 / i5-1135G7 / i3-1115G4 Processor TDP locked at 15W
CPU Cooler (Type)	Heatsink
Memory	Two 260-pin DDR4 3200 MHz SO-DIMM socket, supports up to 64GB Max (non ECC only)
Power Supply	DC in
Adapter	24V 90W Screw Type Adapter
System Fan	Fanless
Speaker	2W x 2
Camera	2.0MP WebCam with external cover (optional)
Wireless LAN	Optional WIFI/BT Module
Bluetooth	Optional WIFI/BT Module
Operating System	Win10 64bit, Linux (Ubuntu 21.04.0/Kernel 5.8)
Expansion Card	1 x M.2 Type B 3042/3052/2242/2260/2280 (with 1 x PCI-e x1 (default) or SATA, USB 3.0 with 1 x SIM card slot, support WWAN+GNSS or SSD 1 x M.2 Key E 2230 support WiFi module and CNVi (1 x PCI-e x1 & USB 2.0 Signal)
Storage	
Solid State Drive	Optional 2.5" SATA SSD Onboard SATA connector and SATA Power
Panel	
LCD Panel	BOE HR215WU1-120
LCD Control Board	DB-LDA001-4-043
Touch Screen	21.5 PCAP
Touch Controller	ILI 2510
External I/O	
USB Port	3 x USB 3.1 Gen 2 1 x USB 3.1 Gen 1
Video Port	2 x DP++
LAN Port	2 x RJ-45
Wireless LAN Antenna	2 x Wireless Antenna for WiFi/BT
Switch	1 x Power Switch

APC-2138

Indicator Light	Power LED on Power Button
Expansion Slots	1 x M.2 Key-B 2242/3042/2260 1 x M.2 Key-E 2230
Mechanical	
Power Type	Wide DC Input 12-24V
Power Connector Type	Mini Din 4-pin DC Jack
Dimension	539.6 x 342.6 x 45.2 mm
Weight	5.5 kg
Color	Black Plastic
Fanless	Fanless
OS Support	Win10 64bit / Linux (Ubuntu 21.04.0/Kernel 5.8)
Reliability	
EMI Test	CE : IEC/EN 62368-1 FCC : Part 15 Class B
Dust and Rain Test	Front IP65
Vibration Test	<p>Random Vibration Operation</p> <p>Reference IEC60068-2-64 Testing procedures</p> <p>Test Fh : Vibration boardband random Test</p> <p>1 Test PSD : 0.00454G²/Hz , 1.5 Grms</p> <p>2 Test frequency : 5~500 Hz</p> <p>3 Test axis : X,Y and Z axis</p> <p>4 Test time : 30 minutes each axis</p> <p>5 System condition : operation mode</p> <p>6 Test curve</p> <p>Sine Vibration Test</p> <p>Reference IEC60068-2-6 Testing procedures</p> <p>Test Fc : Vibration sinusoidal</p> <p>1 Test Acceleration : 2G</p> <p>2 Test frequency : 5~500 Hz</p> <p>3 Sweep : 1 Oct/ per one minute. (logarithmic)</p> <p>4 Test axis : X,Y and Z axis</p> <p>5 Test time :30 min. each axis</p> <p>6 System condition : Non-Operating mode</p> <p>7 Test curve</p> <p>Package Vibration Test:</p> <p>Reference IEC60068-2-64 Testing procedures</p> <p>Test Fh : Vibration boardband random Test</p> <p>1 Test PSD : 0.026G²/Hz , 2.16 Grms</p>

	<p>2 Test frequency : 5~500 Hz</p> <p>3 Test axis : X,Y and Z axis</p> <p>4 Test time : 30 minutes each axis</p> <p>5 Test curve</p>
Mechanical Shock Test	<p>1 Wave form : Half Sine wave</p> <p>2 Acceleration Rate : 10g</p> <p>3 Duration Time : 11ms</p> <p>4 No. of shock : Z axis 300 times</p> <p>5 Test Axis : Z axis</p> <p>6 operation mode</p> <p>7 Reference IEC 60068-2-27 testing procedures</p> <p>Test Eb : Shock Test</p>
Drop Test	<p>Package drop test</p> <p>Reference ISTA 2A, Method :</p> <p>IEC-60068-2-32 Test:Ed</p> <p>Test Ea : Drop Test</p> <p>1 Test phase : One corner, three edges, six faces</p> <p>2 Test high : 96.5cm</p> <p>3 Package weight : 5.5 Kg</p> <p>4 Test drawing</p>
Operating Temperature	0°C ~ 40°C (32°F ~ 104°F)
Operating Humidity	40°C @ 95% Relative Humidity, Non-condensing
Storage Temperature	-10°C ~ 60°C (14°F ~ 140°F)



Note: Specifications are subject to change without notice.

1.4 System Overview

1.4.1 Rear View

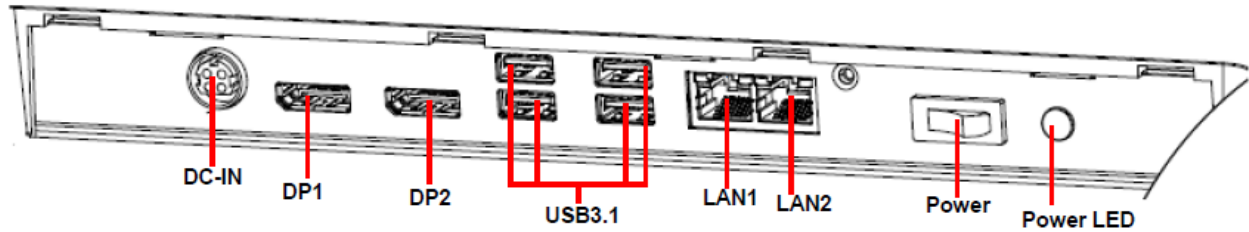

Connectors

Label	Function	Note
DC-IN	DC Power-in connector	
DP1/2	DP connector 1/2	
USB3.1	3 x USB 3.1 Gen 2 connector 1 x USB 3.1 Gen 1 connector	
LAN1/2	RJ-45 Ethernet 1/2	
Power	Power Switch	
Power LED	Power LED on Power Button	

1.5 System Dimensions

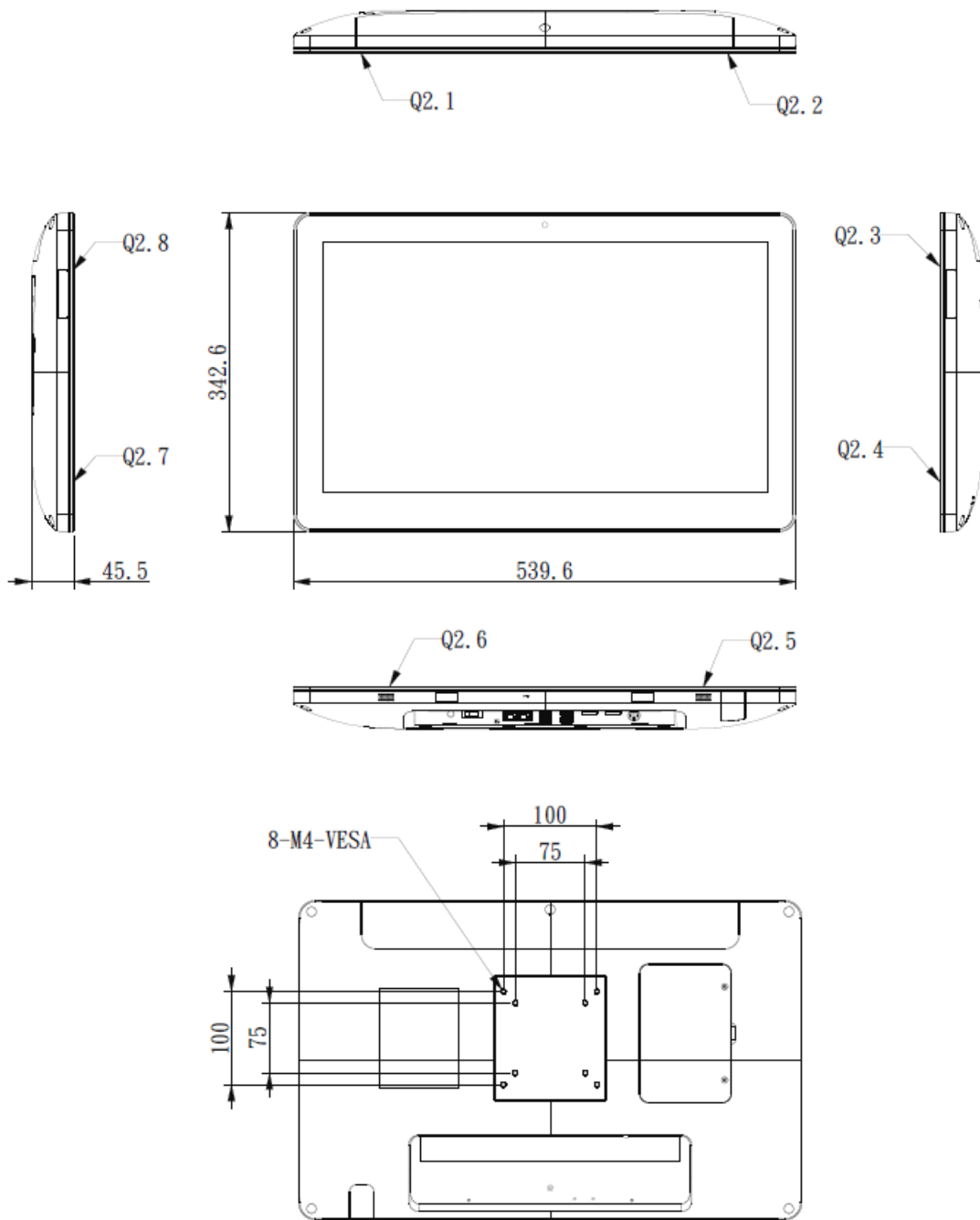

(Unit: mm)

2. Hardware Configuration

For advanced information, please refer to:

- 1- EMX-TGLC included in this manual.



Note: If you need more information, please visit our website:

<http://www.avalue.com.tw>

2.1 Storage Installation

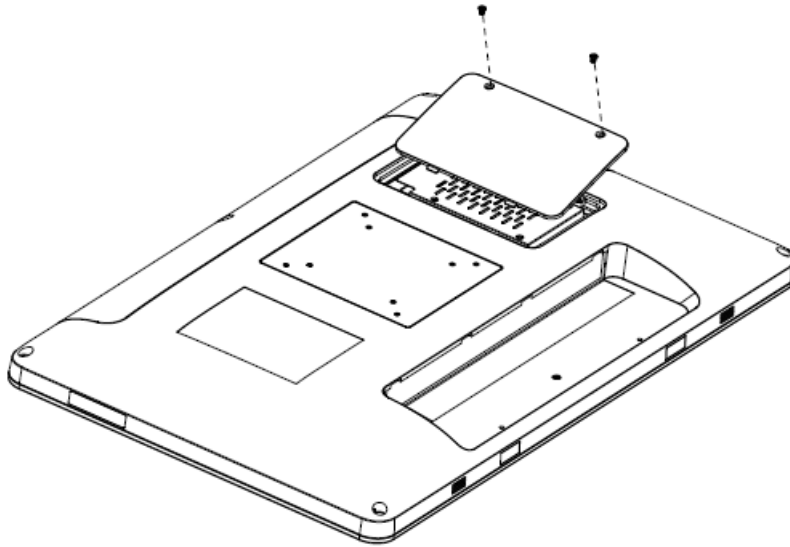

Step 1. Remove 2 screws to release the chassis cover, and remove it.

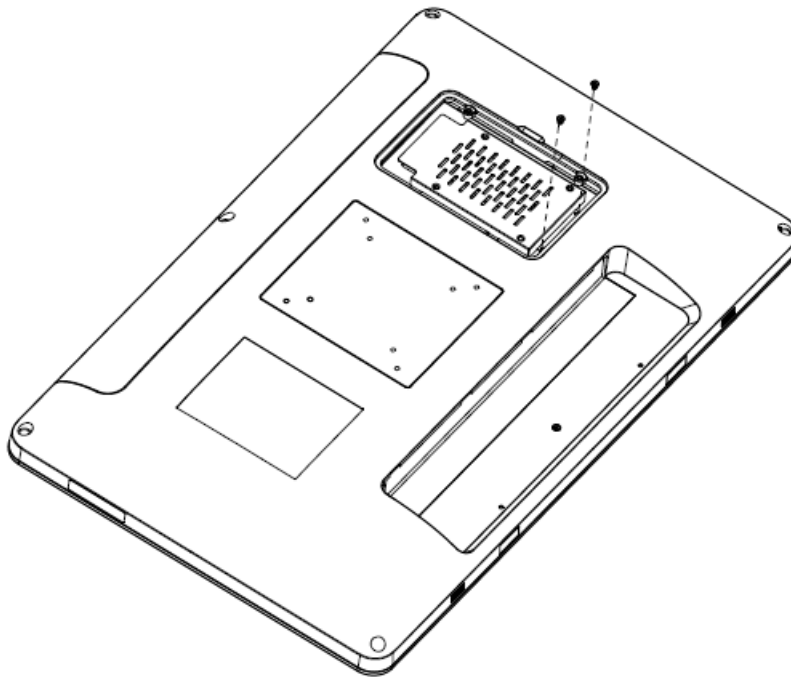

Step 2. Insert the HDD back and fasten 2 screws.

2.2 EMX-TGLC Overview

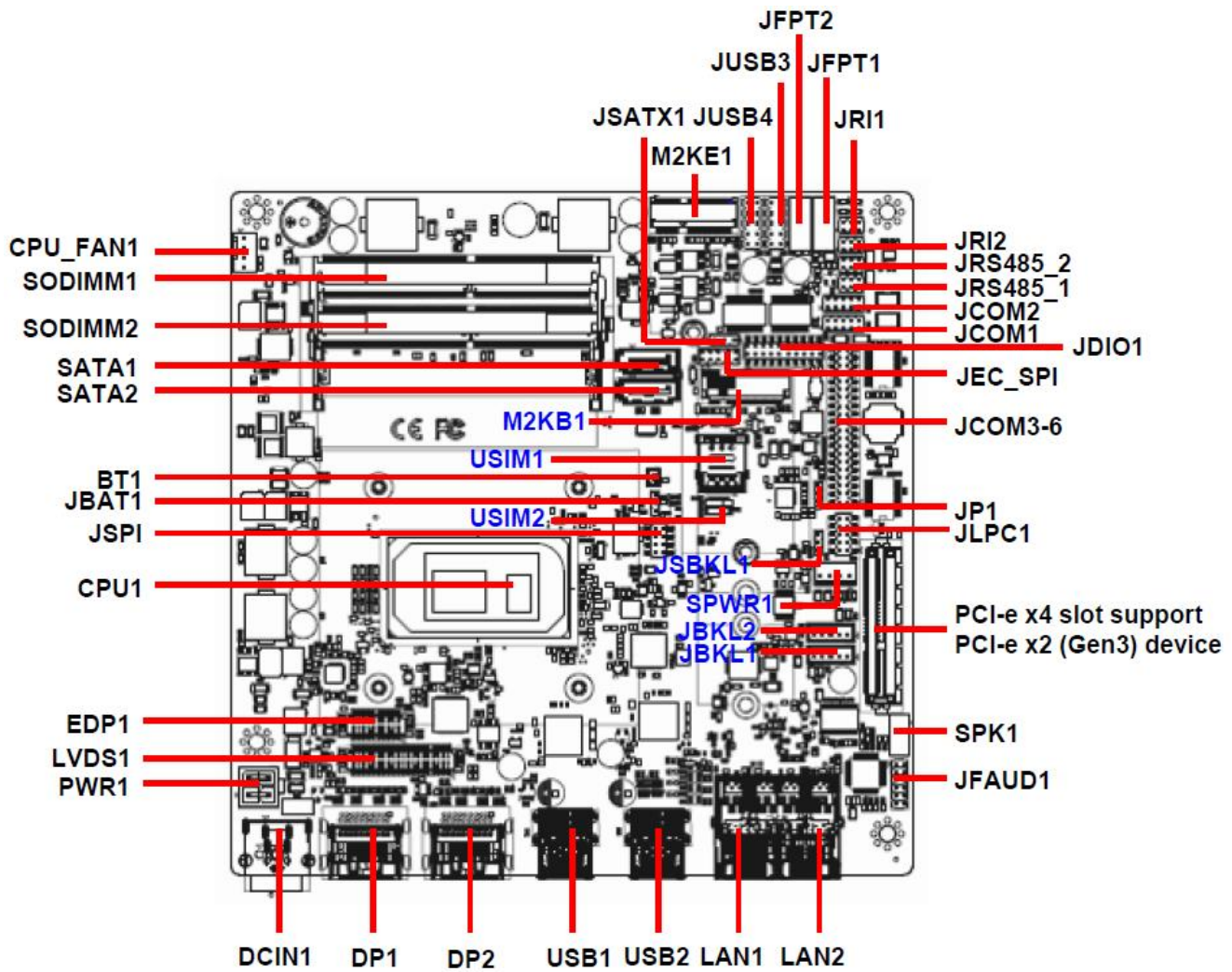

2.3 EMX-TGLC Jumper and Connector List

You can configure your board to match the needs of your application by setting jumpers. A jumper is the simplest kind of electric switch.

It consists of two metal pins and a small metal clip (often protected by a plastic cover) that slides over the pins to connect them. To “close” a jumper you connect the pins with the clip. To “open” a jumper you remove the clip. Sometimes a jumper will have three pins, labeled 1, 2, and 3. In this case, you would connect either two pins.

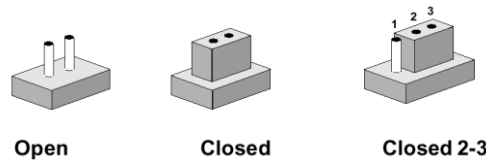

The jumper settings are schematically depicted in this manual as follows:



A pair of needle-nose pliers may be helpful when working with jumpers.

Connectors on the board are linked to external devices such as hard disk drives, a keyboard, or floppy drives. In addition, the board has a number of jumpers that allow you to configure your system to suit your application.

If you have any doubts about the best hardware configuration for your application, contact your local distributor or sales representative before you make any changes.

The following tables list the function of each of the board’s jumpers and connectors.

Jumpers

Label	Function	Note
JRI1/2	Serial port 1/2 pin9 signal select	3 x 2 header, pitch 2.00mm
JSBKL1	LVDS Back Light power selection	3 x 1 header, pitch 2.00mm
JSATX1	AT/ATX Power Mode Select	3 x 1 header, pitch 2.54mm
JP1	M2KB1 Voltage setting	3 x 1 header, pitch 2.00mm
JBAT1	Clear CMOS	2 x 1 wafer, pitch 2.00mm

Connectors

Label	Function	Note
FPT1	Miscellaneous setting connector 1	5 x 2 header, pitch 2.54mm
FPT2	Miscellaneous setting connector 2	5 x 2 header, pitch 2.54mm
SODIMM1/2	206-pin DDR4 SO-DIMM socket	
JFAUD1	Front Audio connector	6 x 2 header, pitch 2.00mm
JBKL1/2	LCD Inverter connector	5 x 1 wafer, pitch 2.00mm

APC-2138

JSPI1	SPI connector	4 x 2 header, pitch 2.00mm
JEC_SPI	EC Debug	5 x 2 header, pitch 2.00mm
JCOM1	Serial Port 1 connector	5 x 2 header, pitch 2.00mm
JCOM2	Serial Port 2 connector	5 x 2 header, pitch 2.00mm
JCOM3-6	Serial Port 3-6 connector	20 x 2 header, pitch 2.00mm
JDIO1	General purpose I/O connector	10 x 2 header, pitch 2.00mm
SPK1	Speaker connector	4 x 1 wafer, pitch 2.00mm
LVDS1	LVDS Connector	20 x 2 wafer, pitch 1.25mm
EDP1	eDP_Panel connector	10 x 2 wafer, pitch 1.25mm
USB1/2	USB connector 1/2	
JUSB3/4	USB connector 3/4	5 x 2 header, pitch 2.54mm
LAN1/2	RJ-45 Ethernet 1/2	
BT1	Battery connector	2 x 1 wafer, pitch 1.25mm
M2KE1	M.2 2230 Type E Slot	
M2KB1	M.2 3042/2242/2260/2280 Type B Slot	
DP1/2	DP connector 1/2	
JRS485_1/2	Serial Port 1/2 RS485/422 Mode connector	3 x 2 header, pitch 2.00mm
JLPC	LPC connector	5 x 2 header, pitch 2.00mm
DCIN1	DC Power-in connector	
PWR1	Power connector	2 x 2 wafer, pitch 4.20mm
SATA1/2	Serial ATA connector 1/2	
SPWR1	SATA Power connector 1	4 x 1 wafer, pitch 2.54mm
USIM1	USIM card slot	
USIM2	USIM connector	10 x 1 header, pitch 0.50mm
CPU_FAN1	CPU fan connector	4 x 1 wafer, pitch 2.54mm
PCIEX4_1	PCIe x4 connector	

2.4 EMX-TGLC Jumpers & Connectors settings

2.4.1 Serial port 1/2 pin9 signal select (JRI1/JRI2)

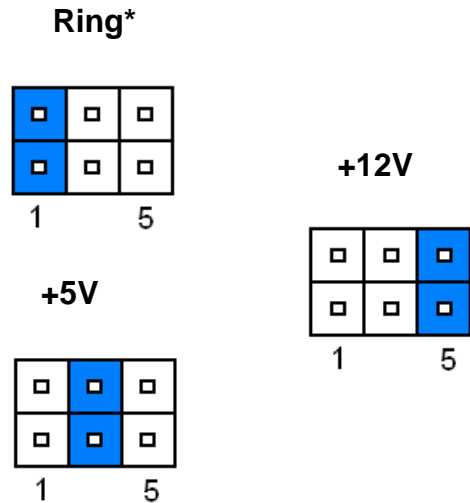
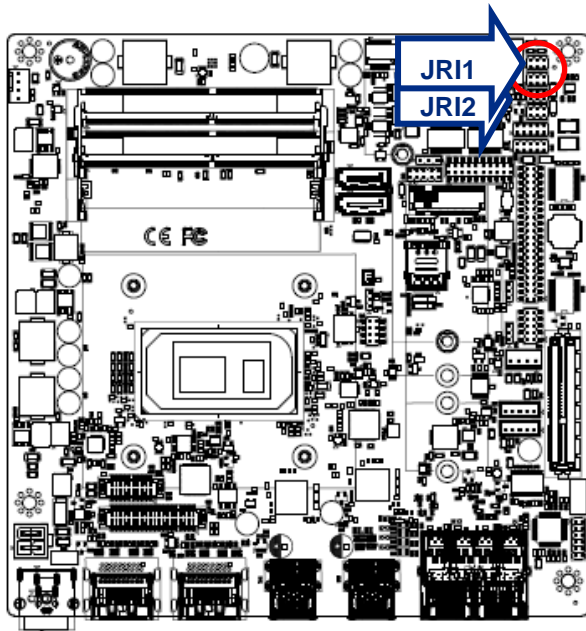

* Default

2.4.2 LVDS Back Light power selection (JSBKL1)

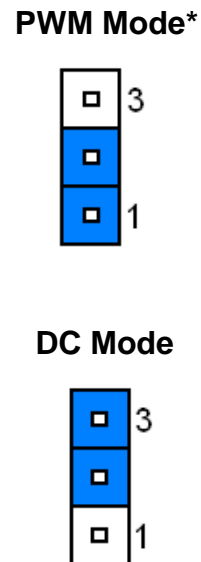
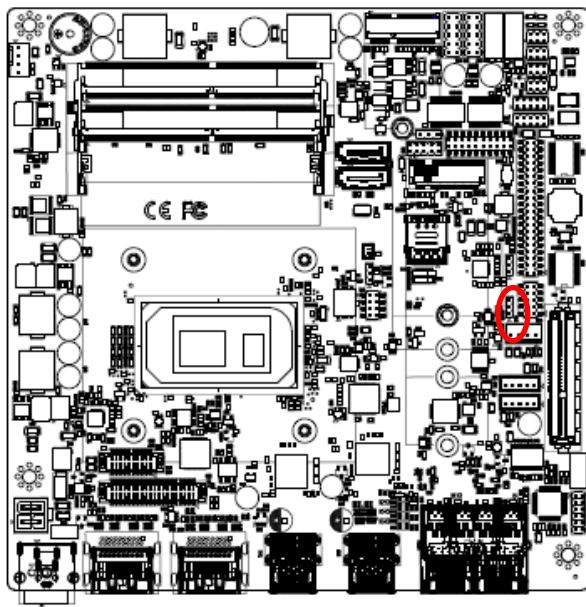

* Default

2.4.3 AT/ATX Power Mode Select (JSATX1)

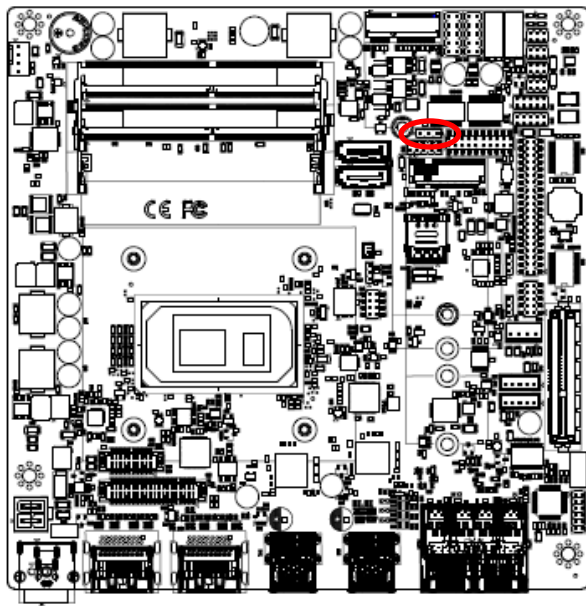

ATX*

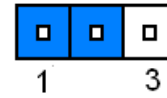

AT

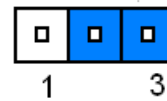

* Default

2.4.4 M2KB1 Voltage setting (JP1)

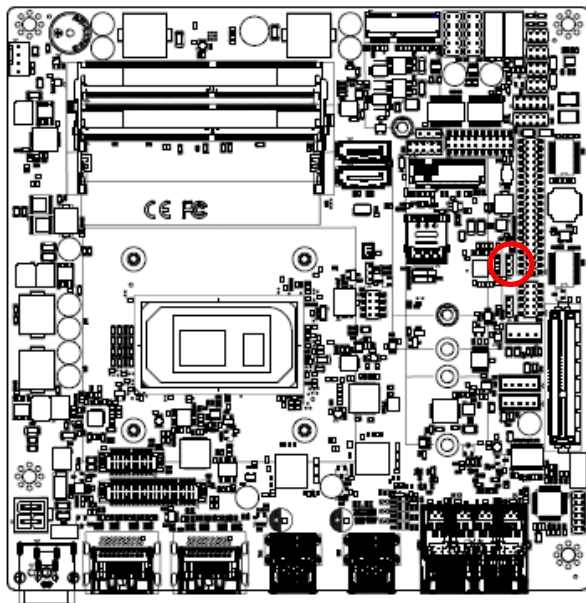

+3.8V

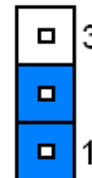

+3.3V*

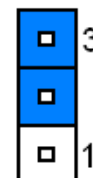

* Default

2.4.5 Clear CMOS (JBAT1)

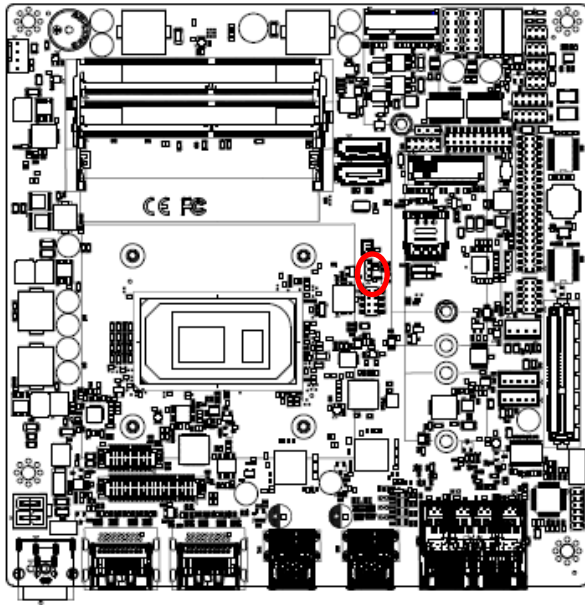

Protect*

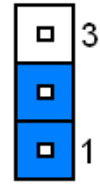

Clear CMOS

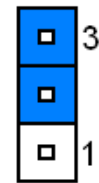

* Default

2.4.6 LCD Inverter connector (JBKL1)

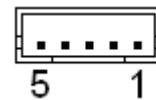
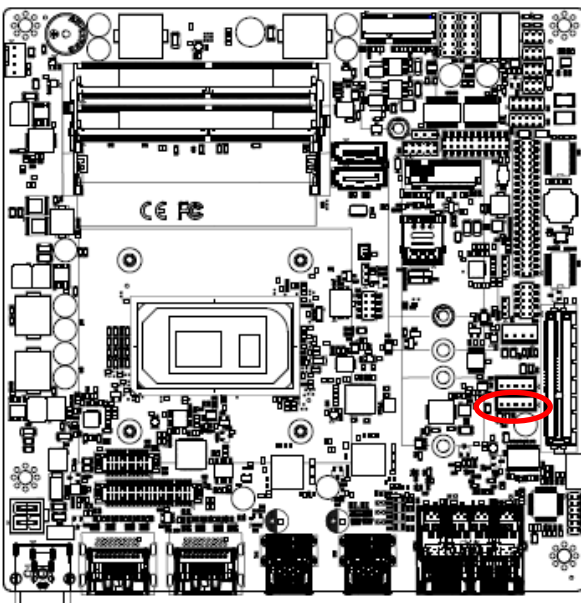

PIN	Signal
1	+12V
2	GND
3	LVDS_BKLT_EN
4	LVDS_BKLTCTL
5	+5V

2.4.7 LCD Inverter connector (JBKL2)

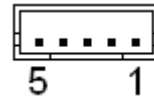
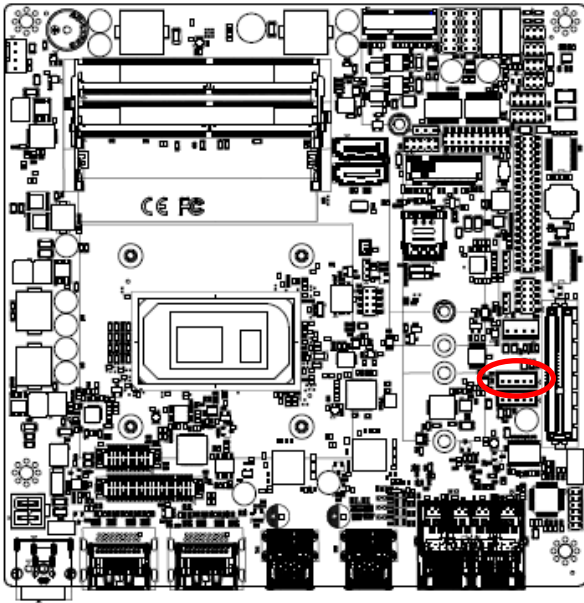

PIN	Signal
1	+12V
2	GND
3	EDP2_BKLTEN
4	EDP2_BKLT_CTL
5	+5V

2.4.8 LVDS connector (LVDS1)

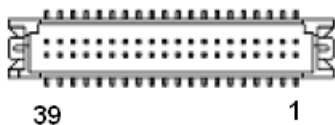
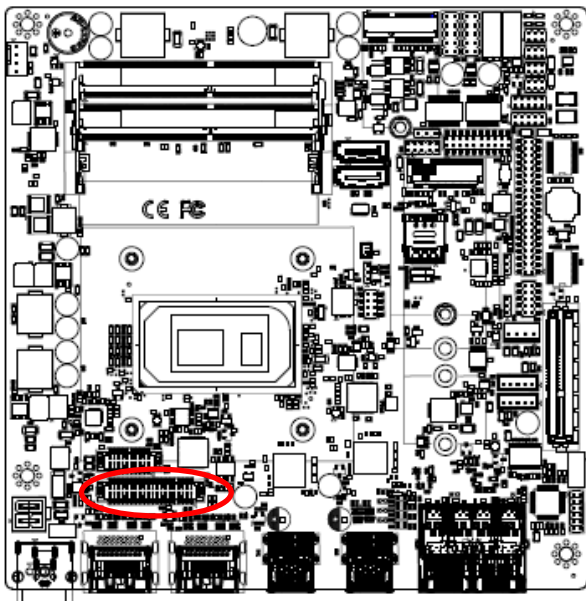

Signal	PIN	PIN	Signal
+V5S_LVDS	2	1	+ V3.3S_LVDS
+V5S_LVDS	4	3	+ V3.3S_LVDS
NC	6	5	NC
GND	8	7	GND
LVDS_DATA0_P	10	9	LVDS_DATA1_P
LVDS_DATA0_N	12	11	LVDS_DATA1_N
GND	14	13	GND
LVDS_DATA2_P	16	15	LVDS_DATA3_P
LVDS_DATA2_N	18	17	LVDS_DATA3_N
GND	20	19	GND
LVDS_DATA4_P	22	21	LVDS_DATA5_P
LVDS_DATA4_N	24	23	LVDS_DATA5_N
GND	26	25	GND
LVDS_DATA6_P	28	27	LVDS_DATA7_P
LVDS_DATA6_N	30	29	LVDS_DATA7_N
GND	32	31	GND
LVDS_CLK1_P	34	33	LVDS_CLK2_P
LVDS_CLK1_N	36	35	LVDS_CLK2_N
GND	38	37	GND
+V12S_LVDS	40	39	+V12S_LVDS

2.4.9 eDP_Panel connector (EDP1)

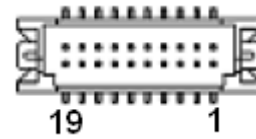
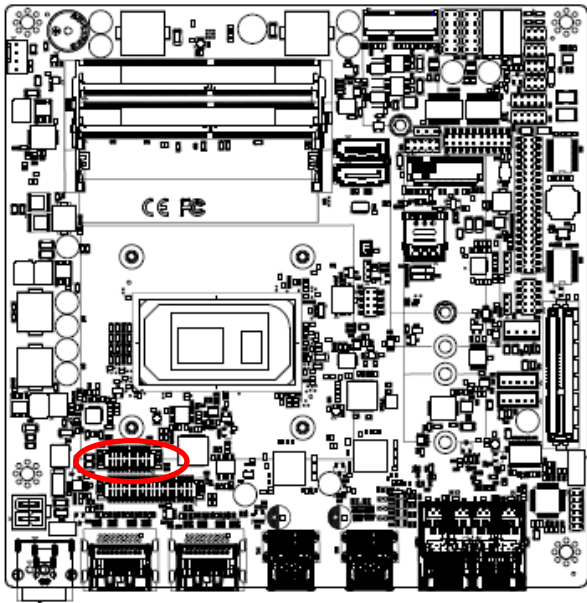

Signal	PIN	PIN	Signal
GND	1	2	GND
EDP_PANEL_TXN0	3	4	EDP_PANEL_TXN3
EDP_PANEL_TXP0	5	6	EDP_PANEL_TXP3
GND	7	8	NC
EDP_PANEL_TXN1	9	10	GND
EDP_PANEL_TXP1	11	12	EDP_PANEL_AUXN
GND	13	14	EDP_PANEL_AUXP
EDP_PANEL_TXN2	15	16	GND
EDP_PANEL_TXP2	17	18	EDP_PANEL_HPDP
+V35_EDP	19	20	+V35_EDP

2.4.10 General purpose I/O connector (DIO1)

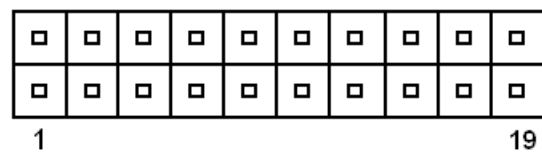
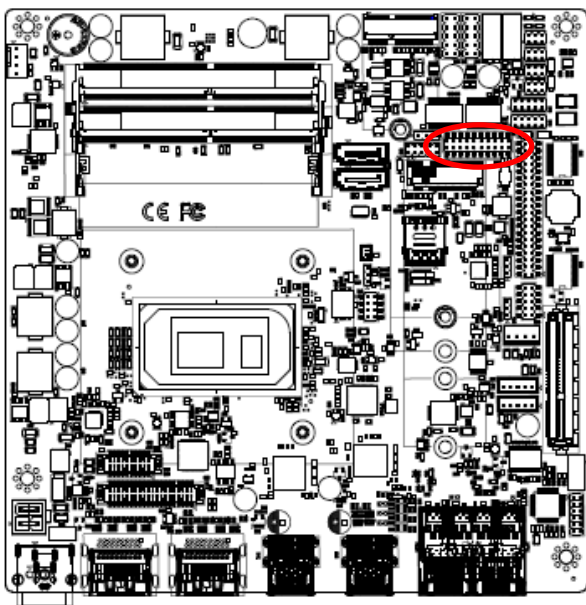

Signal	PIN	PIN	Signal
DI0	1	2	DO0
DI1	3	4	DO1
DI2	5	6	DO2
DI3	7	8	DO3
DI4	9	10	DO4
DI5	11	12	DO5
DI6	13	14	DO6
DI7	15	16	DO7
SMB_SCL_S0_3P3EXT	17	18	SMB_SDA_S0_3P3EXT
GND	19	20	+5V (Max current = 0.5A)

2.4.11 Serial port1 connector (JCOM1)

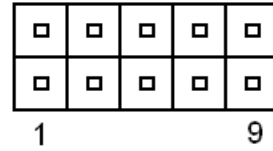
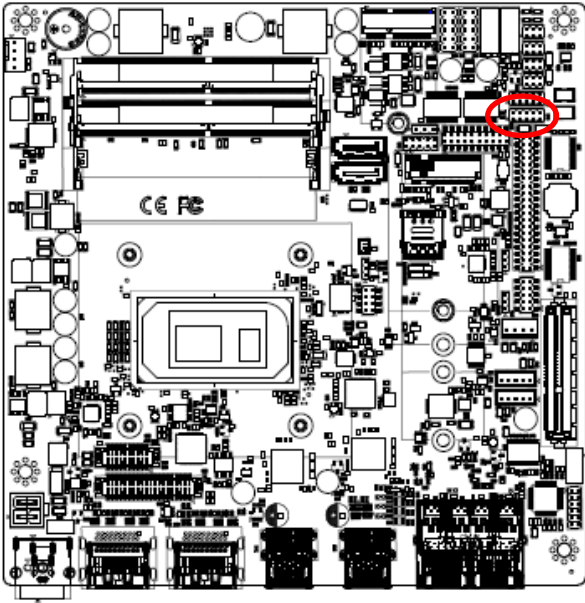

Signal	PIN	PIN	Signal
COM_DCD#_1	1	2	COM_RXD_1
COM_TXD_1	3	4	COM_DTR#_1
GND	5	6	COM_DSR#_1
COM_RTS#_1	7	8	COM_CTS#_1
COM_RI#_1	9	10	NC

2.4.12 Serial port2 connector (JCOM2)

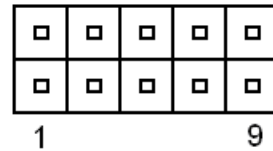
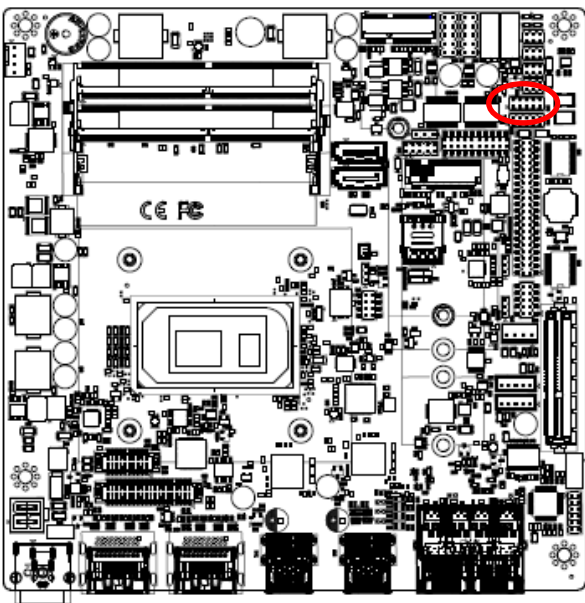

Signal	PIN	PIN	Signal
COM_DCD#_2	1	2	COM_RXD_2
COM_TXD_2	3	4	COM_DTR#_2
GND	5	6	COM_DSR#_2
COM_RTS#_2	7	8	COM_CTS#_2
COM_RI#_2	9	10	NC

2.4.13 Serial port 3/4/5/6 connector (JCOM3/4/5/6)

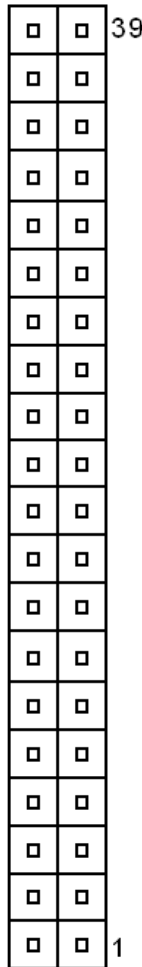
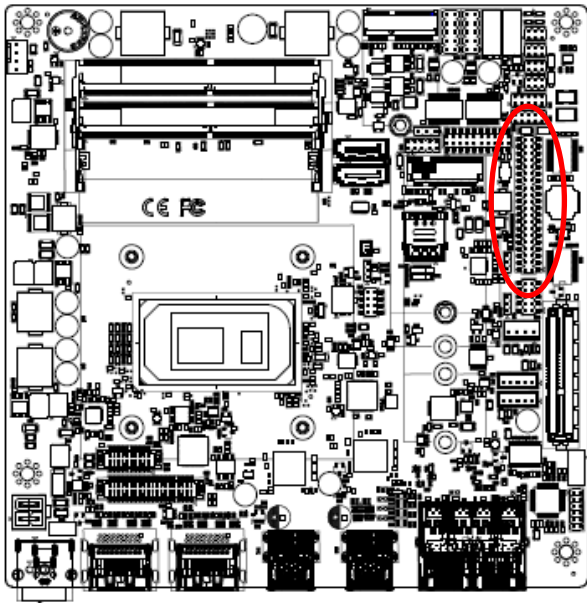

Signal	PIN	PIN	Signal
NC	40	39	COM_RI#_6
COM_CTS#_6	38	37	COM_RTS#_6
COM_DSR#_6	36	35	GND
COM_DTR#_6	34	33	COM_TXD_6
COM_RXD_6	32	31	COM_DCD#_6
NC	30	29	COM_RI#_5
COM_CTS#_5	28	27	COM_RTS#_5
COM_DSR#_5	26	25	GND
COM_DTR#_5	24	23	COM_TXD_5
COM_RXD_5	22	21	COM_DCD#_5
NC	20	19	COM_RI#_4
COM_CTS#_4	18	17	COM_RTS#_4
COM_DSR#_4	16	15	GND
COM_DTR#_4	14	13	COM_TXD_4
COM_RXD_4	12	11	COM_DCD#_4
NC	10	9	COM_RI#_3
COM_CTS#_3	8	7	COM_RTS#_3
COM_DSR#_3	6	5	GND
COM_DTR#_3	4	3	COM_TXD_3
COM_RXD_3	2	1	COM_DCD#_3

2.4.14 Serial Port 1/2 RS485/422 Mode connector (JRS485_1/2)

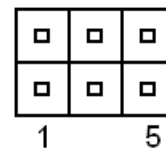
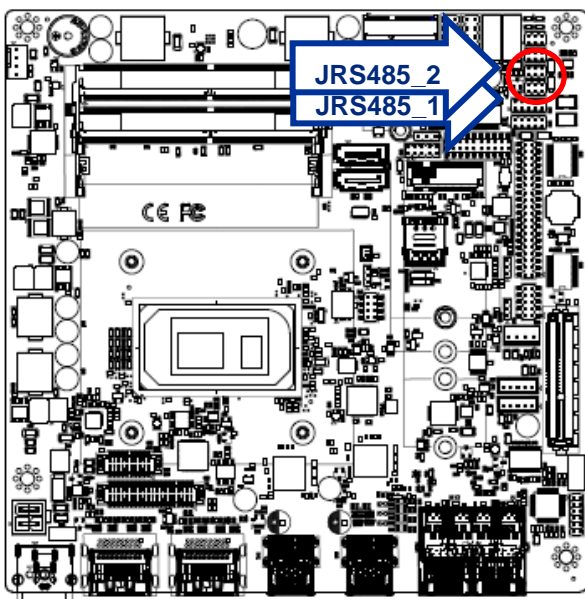

Signal	PIN	PIN	Signal
485_422TX-	1	2	422RX-
485_422TX+	3	4	422RX+
+5V	5	6	GND

2.4.15 SATA Power connector 1 (SPWR1)

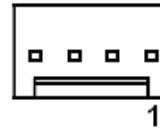
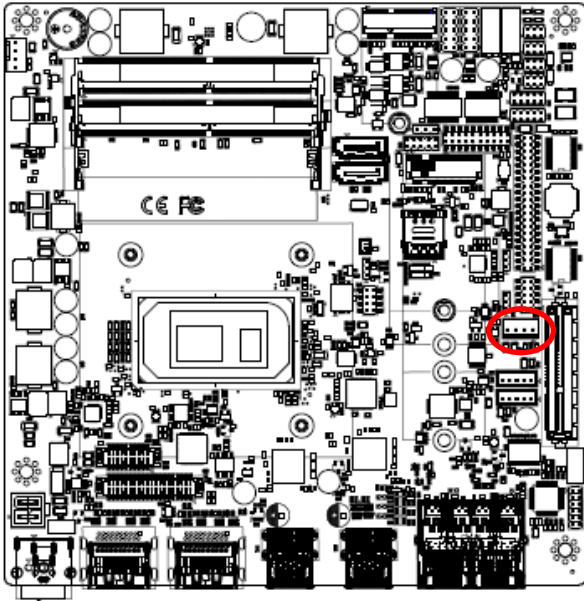

PIN	Signal
1	+V5S_SATA
2	GND
3	GND
4	+V12S_SATA

2.4.16 Power connector (PWR1)

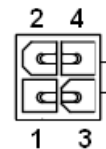
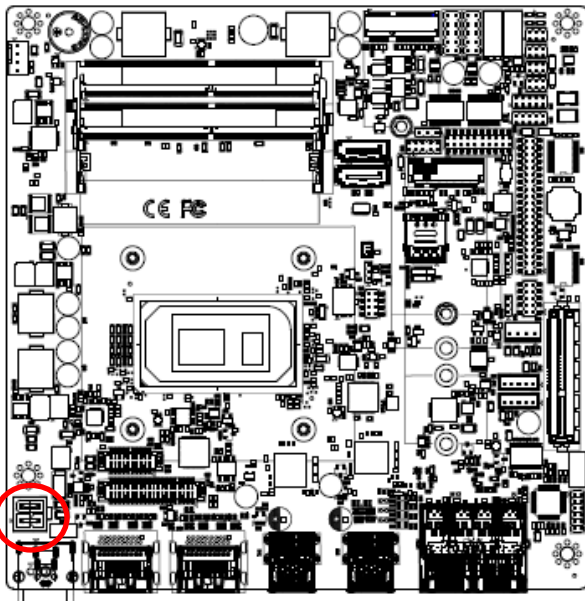

Signal	PIN	PIN	Signal
GND	2	4	+VIN
GND	1	3	+VIN

2.4.17 USB connector 3 (JUSB3)

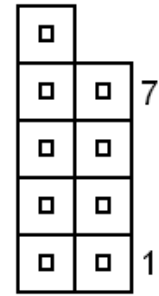
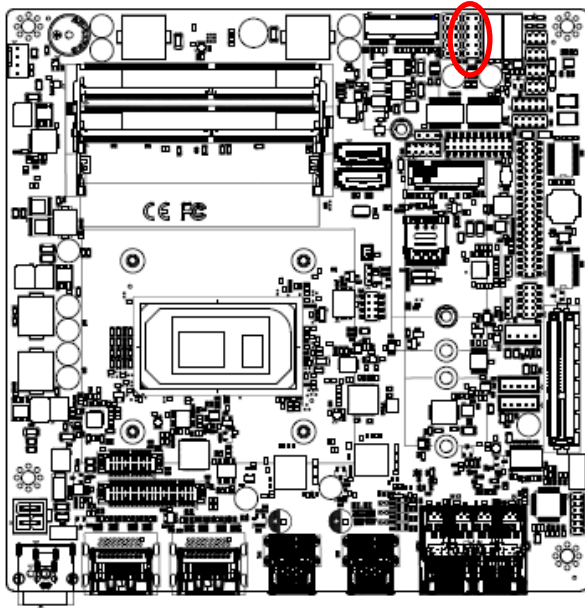

Signal	PIN	PIN	Signal
+V5A_USB56	1	2	+V5A_USB56
USB_DN5	3	4	USB_DN6
USB_DP5	5	6	USB_DP6
GND	7	8	GND
		10	GND

2.4.18 USB connector 4 (JUSB4)

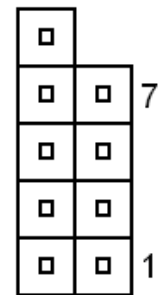
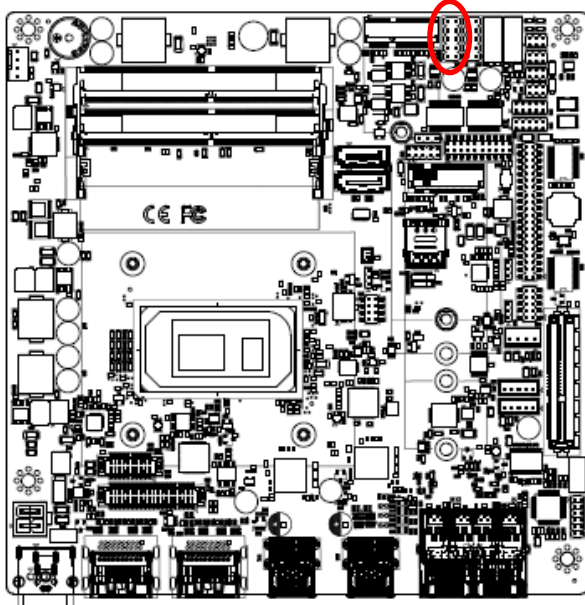

Signal	PIN	PIN	Signal
+V5A_USB78	1	2	+V5A_USB78
USB_DN7	3	4	USB2_DN8
USB_DP7	5	6	USB2_DP8
GND	7	8	GND
		10	GND

2.4.19 Speaker connector (SPK1)

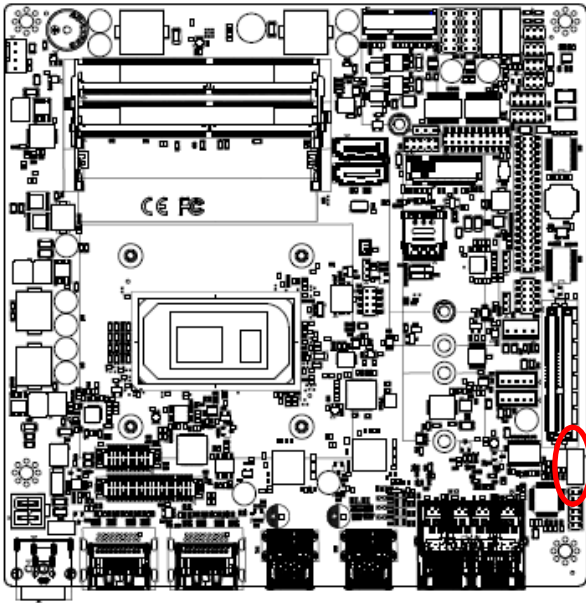

Signal	PIN
SPK_L+	1
SPK_L-	2
SPK_R+	3
SPK_R-	4

2.4.20 SPI connector (JSPI1)

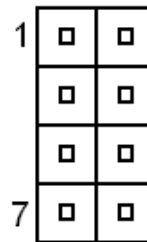
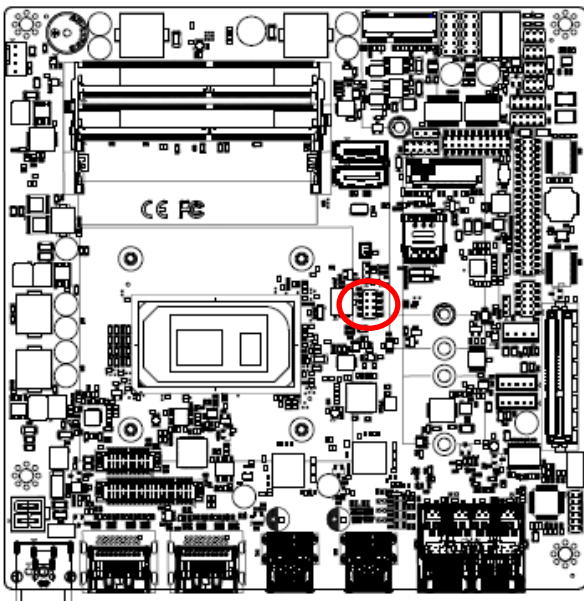

Signal	PIN	PIN	Signal
+V3.3A_1.8A_SPI	1	2	GND
SPI0_CS0#	3	4	SPI0_BIOS_CLK
SPI0_BIOS_MISO	5	6	SPI0_BIOS_MOSI
BIOS_HOLD#	7	8	BIOS_WP#

2.4.21 Battery connector (BT1)

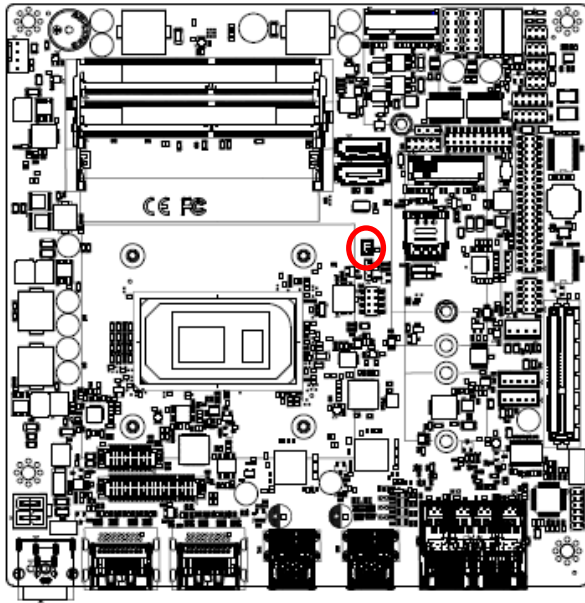

PIN	Signal
1	+RTCBAT
2	GND

2.4.22 Audio connector (JFAUD1)

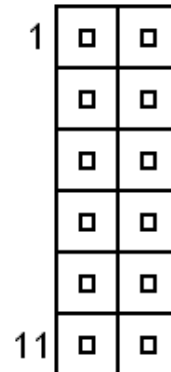
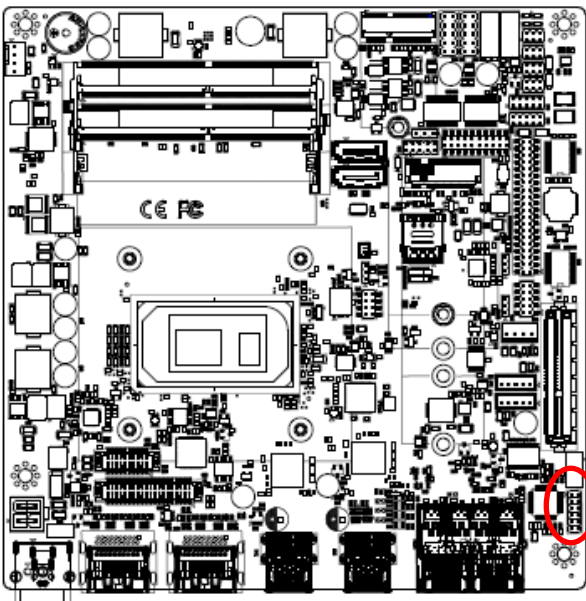

Signal	PIN	PIN	Signal
LINEOUT_R	1	2	LINEOUT_L
GND_AUD	3	4	GND_AUD
LINEIN_R	5	6	LINEIN_L
MICIN_R	7	8	MICIN_L
LINEOUT1_JD	9	10	LINE1-JD
MIC1_JD	11	12	GND_AUD

2.4.23 EC Debug (JEC_SPI)

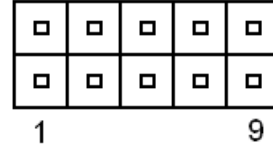
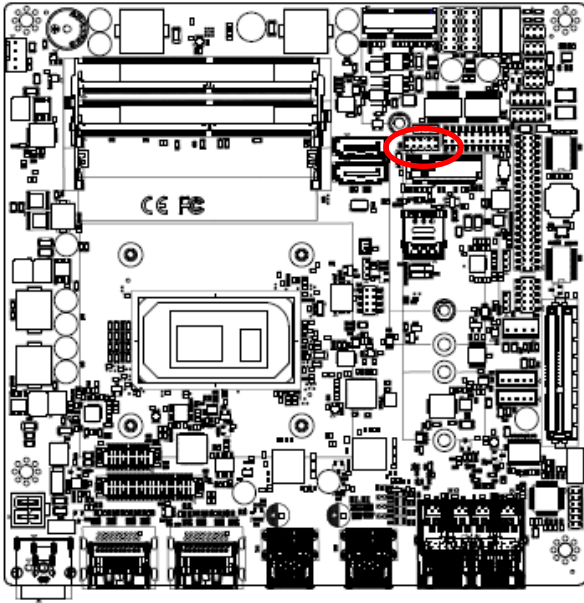

Signal	PIN	PIN	Signal
+V3.3A_EC	1	2	GND
EC_FSCE#	3	4	EC_FSCK
EC_FMISO	5	6	EC_FMOSI
EC_HOLD#	7	8	NC
EC_SMCLK_DEBUG	9	10	EC_SMDAT_DEBUG

2.4.24 Miscellaneous setting connector 1 (JFPT1)

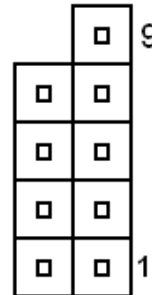
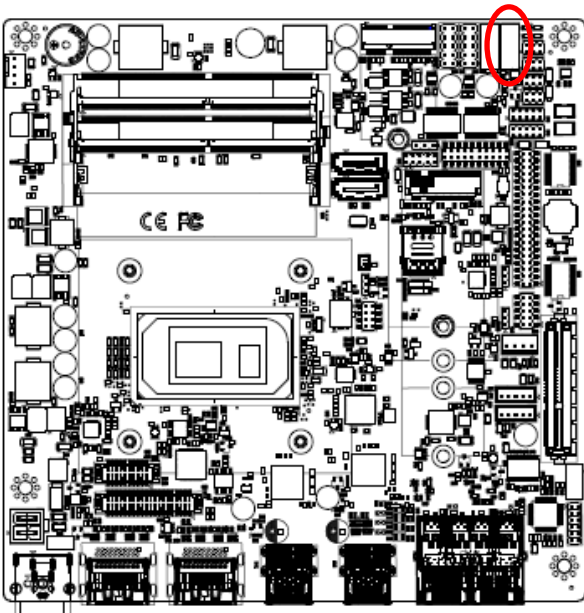

Signal	PIN	PIN	Signal
		9	NC
-PWR_BNT	8	7	-Reset
+PWR_BNT	6	5	+Reset
-PWR_LED	4	3	-HD_LED
+PWR_LED	2	1	+HD_LED

2.4.25 Miscellaneous setting connector 2 (FPT2)

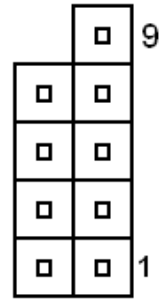
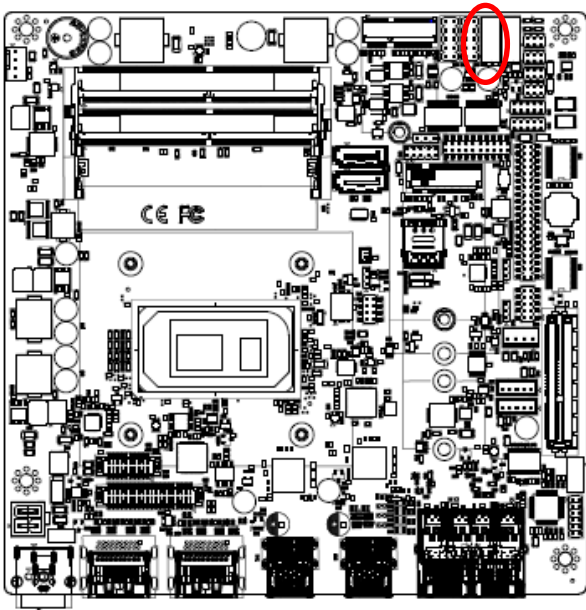

Signal	PIN	PIN	Signal
		9	NC
GND	8	7	Speaker-
BLK_DN	6	5	NC
BLK_UP	4	3	NC
BLK_VR(10K)	2	1	Speaker+

2.4.26 LPC connector (JLPC1)

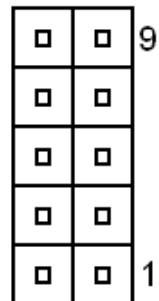
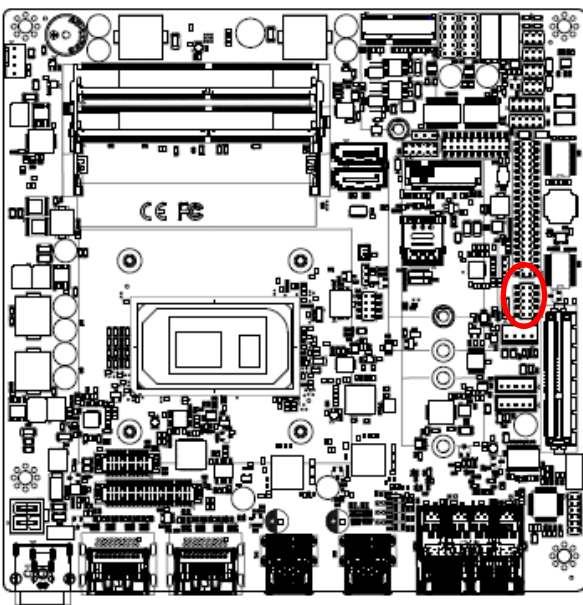

Signal	PIN	PIN	Signal
LPC_AD0	1	2	+3.3V
LPC_AD1	3	4	PLT_BUF_RST#
LPC_AD2	5	6	LPC_LFRAME#
LPC_AD3	7	8	CLK_24M_80
LPC_SERIRQ	9	10	GND

2.4.27 CPU fan connector (CPU_FAN1)

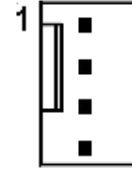
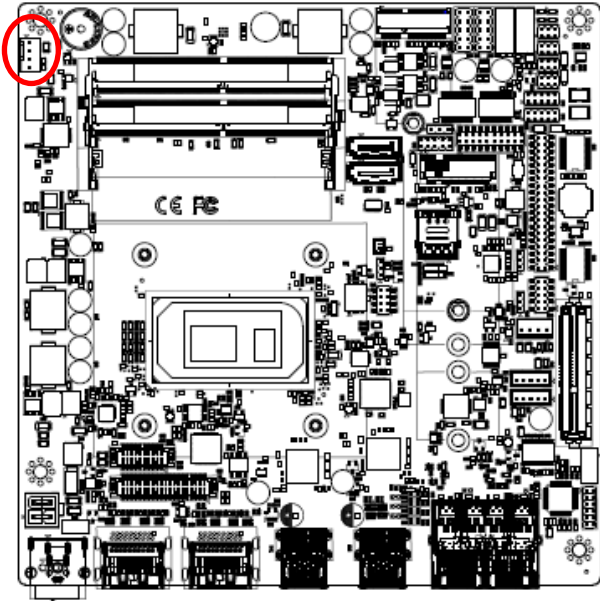

Signal	PIN
GND	1
+12V	2
CPU_FANIN	3
FAN_PWM0	4

2.4.28 USIM connector (USIM2)

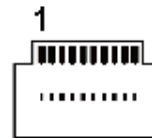
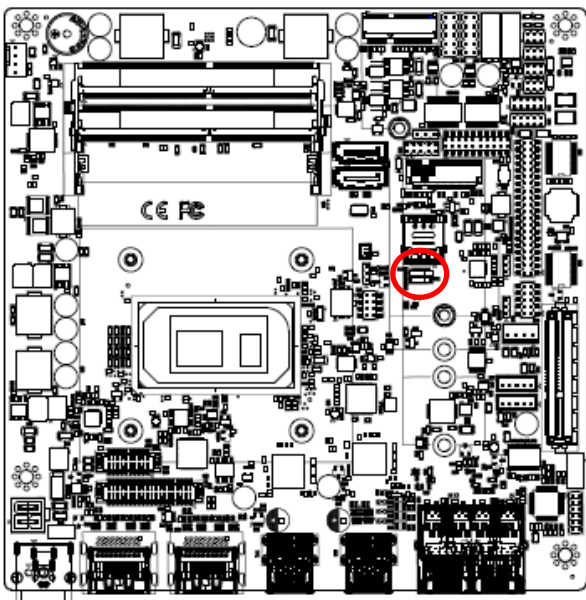

Signal	PIN
+VCC_SIM	1
GND	2
UIM_R_RESET#	3
NC	4
GND	5
UIM_R_CLK	6
UIM_R_DATA	7
GND	8
SIM_DET	9
NC	10

3. BIOS Setup

3.1 Introduction

The BIOS setup program allows users to modify the basic system configuration. In this following chapter will describe how to access the BIOS setup program and the configuration options that may be changed.

3.2 Starting Setup

The AMI BIOS™ is immediately activated when you first power on the computer. The BIOS reads the system information contained in the NVRAM and begins the process of checking out the system and configuring it. When it finishes, the BIOS will seek an operating system on one of the disks and then launch and turn control over to the operating system.

While the BIOS is in control, the Setup program can be activated in one of two ways:

By pressing or <F2> immediately after switching the system on, or

By pressing the or <F2> key when the following message appears briefly at the left-top of the screen during the POST (Power On Self Test).

Press or <F2> to enter SETUP

If the message disappears before you respond and you still wish to enter Setup, restart the system to try again by turning it OFF then ON or pressing the "RESET" button on the system case. You may also restart by simultaneously pressing <Ctrl>, <Alt>, and <Delete> keys. If you do not press the keys at the correct time and the system does not boot, an error message will be displayed and you will again be asked to.

Press F1 to Continue, DEL to enter SETUP

3.3 Using Setup

In general, you use the arrow keys to highlight items, press <Enter> to select, use the PageUp and PageDown keys to change entries, press <F1> for help and press <Esc> to quit. The following table provides more detail about how to navigate in the Setup program using the keyboard.

Button	Description
↑↓→←	Move
Enter	Select
+/-	Value
Esc	Exit
F1	General Help
F2	Previous Values
F3	Optimized Defaults
F4	Save & Exit Setup
<K>	Scroll help area upwards
<M>	Scroll help area downwards

- **Navigating Through The Menu Bar**

Use the left and right arrow keys to choose the menu you want to be in.



Note: Some of the navigation keys differ from one screen to another.

- **To Display a Sub Menu**

Use the arrow keys to move the cursor to the sub menu you want. Then press <Enter>. A “>” pointer marks all sub menus.

3.4 Getting Help

Press F1 to pop up a small help window that describes the appropriate keys to use and the possible selections for the highlighted item. To exit the Help Window press <Esc> or <Enter> key.

3.5 In Case of Problems

If, after making and saving system changes with Setup, you discover that your computer no longer is able to boot, the AMI BIOS supports an override to the NVRAM settings which resets your system to its defaults.

The best advice is to only alter settings which you thoroughly understand. To this end, we strongly recommend that you avoid making any changes to the chipset defaults. These defaults have been carefully chosen by both BIOS Vendor and your systems manufacturer to provide the absolute maximum performance and reliability. Even a seemingly small change to the chipset setup has the potential for causing you to use the override.

3.6 BIOS setup

Once you enter the Aptio Setup Utility, the Main Menu will appear on the screen. The Main Menu allows you to select from several setup functions and exit choices. Use the arrow keys to select among the items and press <Enter> to accept and enter the sub-menu.

3.6.1 Main Menu

This section allows you to record some basic hardware configurations in your computer and set the system clock.

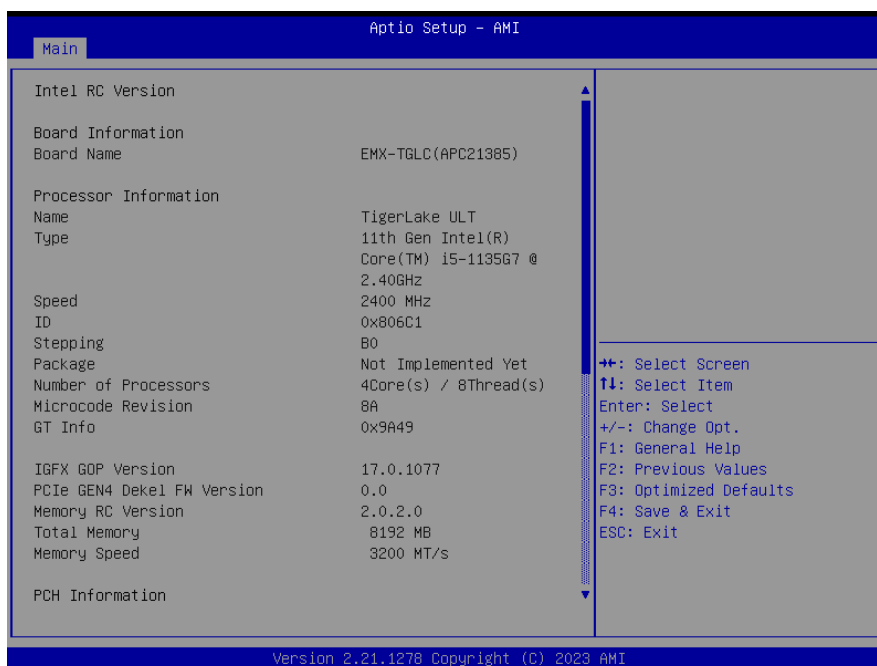
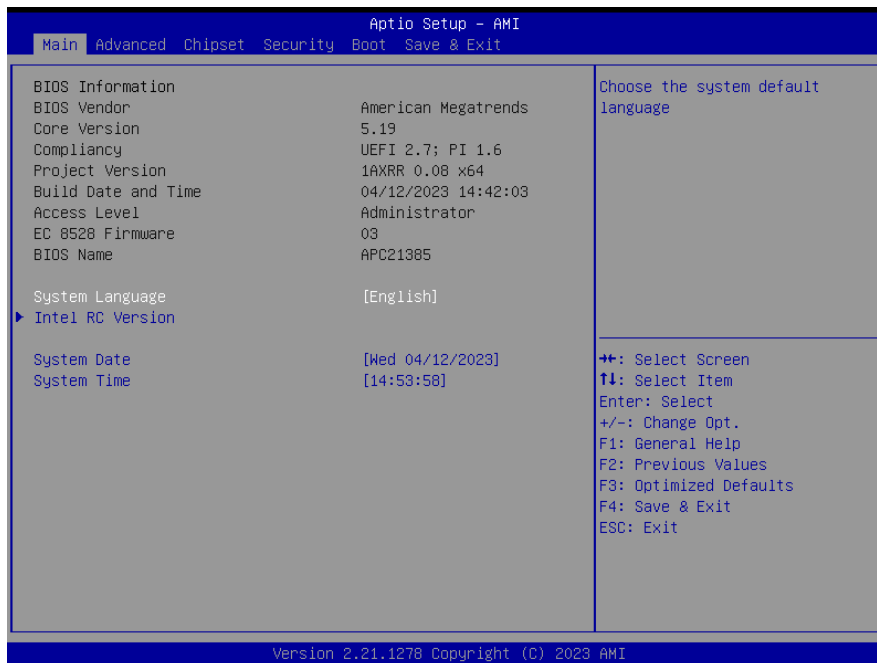

3.6.1.1 System Language

This option allows choosing the system default language.

3.6.1.2 System Date

Use the system date option to set the system date. Manually enter the day, month and year.

3.6.1.3 System Time

Use the system time option to set the system time. Manually enter the hours, minutes and seconds.



Note: The BIOS setup screens shown in this chapter are for reference purposes only, and may not exactly match what you see on your screen.

Visit the Avalue website (www.avalue.com.tw) to download the latest product and BIOS information.

3.6.2 Advanced Menu

This section allows you to configure your CPU and other system devices for basic operation through the following sub-menus.

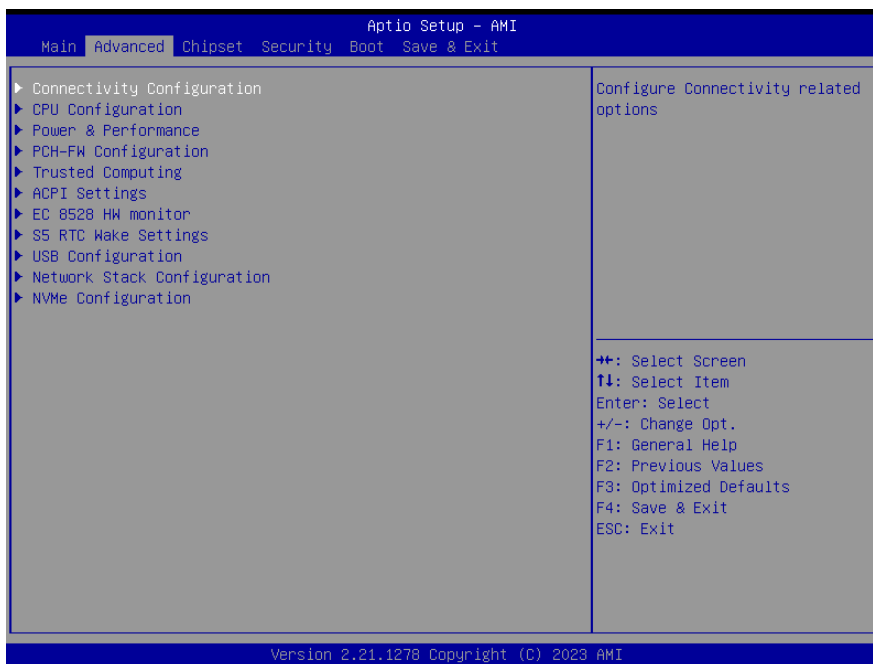

3.6.2.1 Connectivity Configuration



Item	Options	Description
CNVi Mode	Disable Integrated[Default] Auto Detection	This option configures Connectivity. [Auto Detection] means that if Discrete solution is discovered it will be enabled by default. Otherwise Integrated solution (CNVi) will be enabled; [Disable Integrated] disables Integrated Solution. NOTE: When CNVi is present, the GPIO pins that are used for radio

3.6.2.2 CPU Configuration

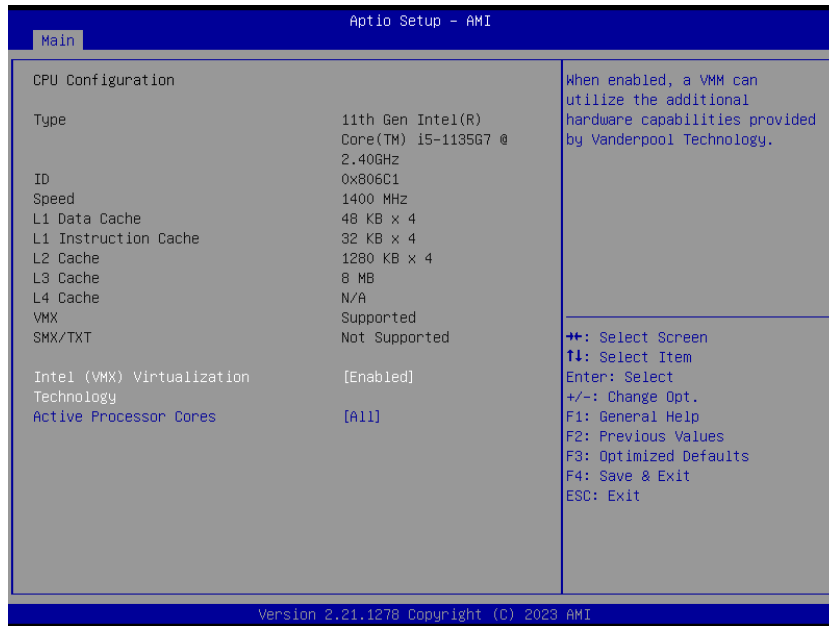

Item	Options	Description
Intel (VMX) Virtualization Technology	Disabled Enabled[Default],	When enabled, a VMM can utilize the additional hardware capabilities provided by Vanderpool Technology.

Active Processor Cores	All[Default], 1/2/3	Number of cores to enable in each processor package.
------------------------	------------------------	--

3.6.2.3 Power & Performance



3.6.2.3.1 CPU - Power Management Control

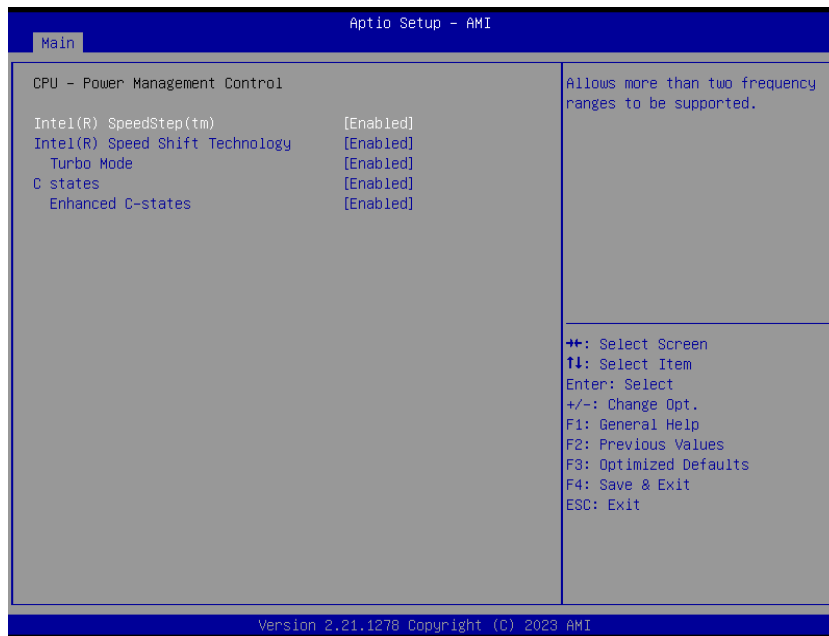

Item	Options	Description
Intel(R) SpeedStep(tm)	Disabled Enabled[Default],	Allows more than two frequency ranges to be supported.
Intel(R) Speed Shift	Disabled	Enable/Disable Intel(R) Speed Shift Technology

Technology	Enabled[Default],	support. Enabling will expose the CPPC v2 interface to allow for hardware controlled P-states.
Turbo Mode	Disabled Enabled[Default],	Enable/Disable processor Turbo Mode (requires EMTTM enabled too). AUTO means enabled.
C states	Disabled Enabled[Default],	Enable/Disable CPU Power Management. Allows CPU to go to C states when it's not 100% utilized.
Enhanced C-states	Disabled Enabled[Default],	Enable/Disable C1E. When enabled, CPU will switch to minimum speed when all cores enter C-State.

3.6.2.4 PCH-FW Configuration

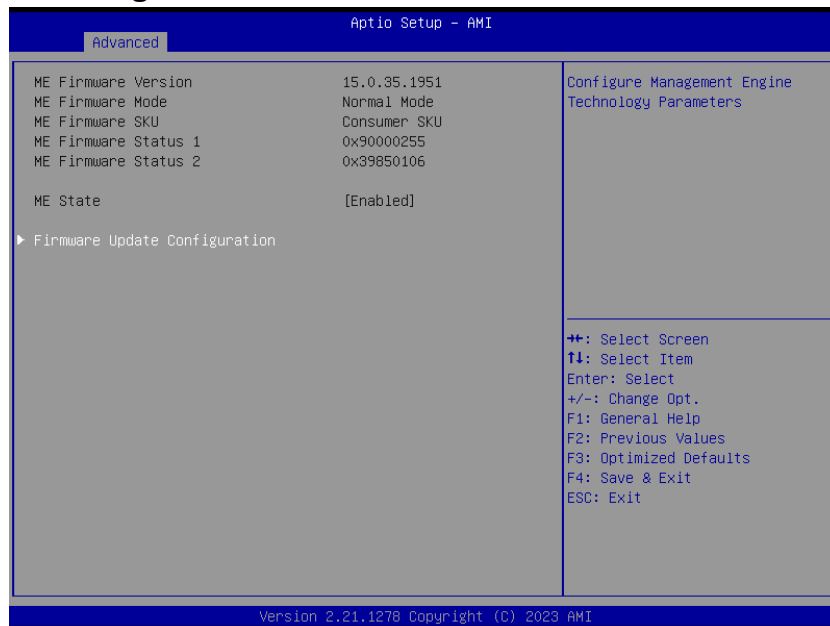

3.6.2.4.1 Firmware Update Configuration

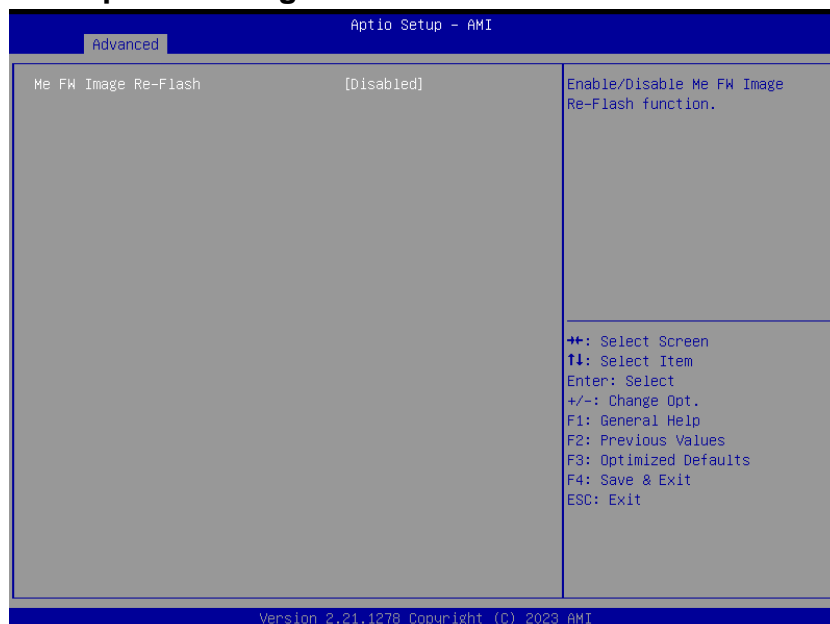

Item	Options	Description
Me FW Image Re-Flash	Disabled[Default], Enabled	Enable/Disable Me FW Image Re-Flash function.

3.6.2.5 Trusted Computing



Item	Options	Description
Security Device Support	Disabled Enabled[Default],	Enables or Disables BIOS support for security device. O.S. will not show Security Device. TCG EFI protocol and INT1A interface will not be available.

3.6.2.6 ACPI Settings



Item	Options	Description
Enable Hibernation	Disabled Enabled[Default],	Enables or Disables System ability to Hibernate (OS/S4 Sleep State). This option may not be effective with some Operating Systems.
ACPI Sleep State	Suspend Disabled, S3 (Suspend to RAM)[Default]	Select the highest ACPI sleep state the system will enter when the SUSPEND button is pressed.

3.6.2.7 EC 8528 H/W monitor

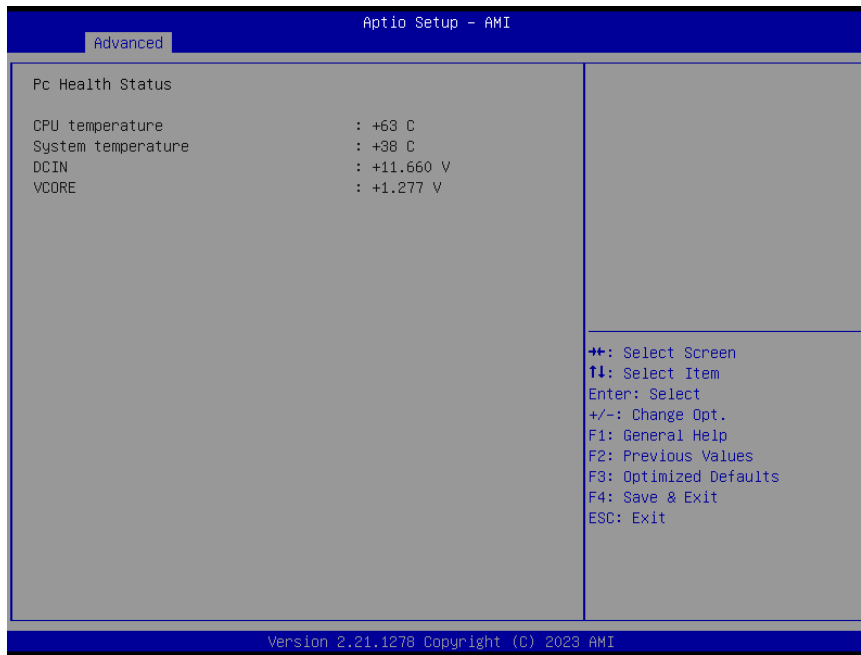

3.6.2.8 S5 RTC Wake Settings



Item	Options	Description
Wake system from S5	Disabled[Default], Fixed Time Dynamic Time	Enable or disable System wake on alarm event. Select FixedTime, system will wake on the hr::min::sec specified. Select DynamicTime, System will wake on the current time + Increase minutes(s).

3.6.2.9 USB Configuration

The USB Configuration menu helps read USB information and configures USB settings.

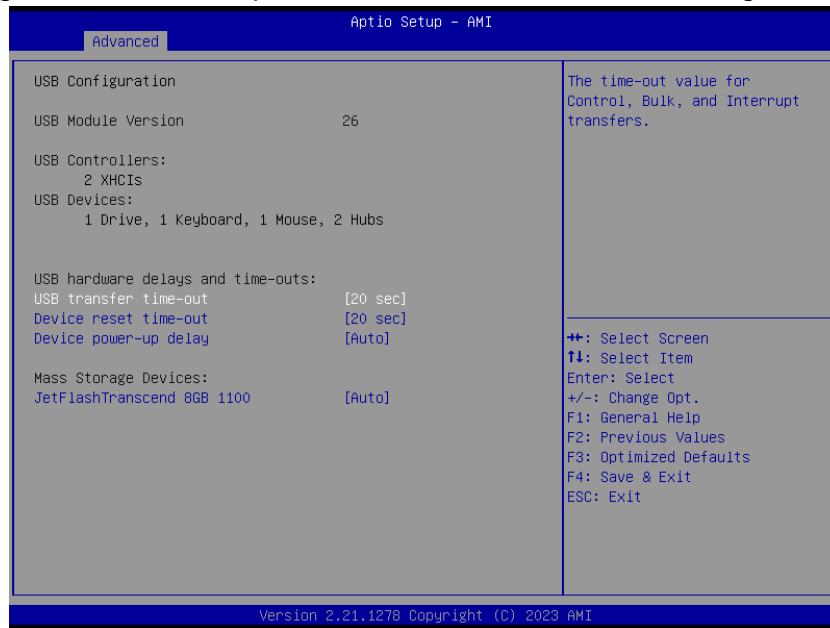

Item	Option	Description
USB transfer time-out	1 sec 5 sec 10 sec 20 sec[Default]	The time-out value for Control, Bulk, and Interrupt transfers.
Device reset time-out	10 sec 20 sec[Default] 30 sec 40 sec	USB mass storage device Start Unit command time-out.
Device power-up delay	Auto[Default] Manual	Maximum time the device will take before it properly reports itself to the Host Controller. 'Auto' uses default value: for a Root port it is 100ms, for a Hub port the delay is taken form Hub descriptor.
Mass Storage Devices	Auto[Default] Floppy Forced FDD Hard Disk CD-ROM	Mass storage device emulation type. 'AUTO' enumerates devices according to their media format. Optical drives are emulated as 'CDROM', drives with no media will be emulated according to a drive type.

3.6.2.10 Network Stack Configuration

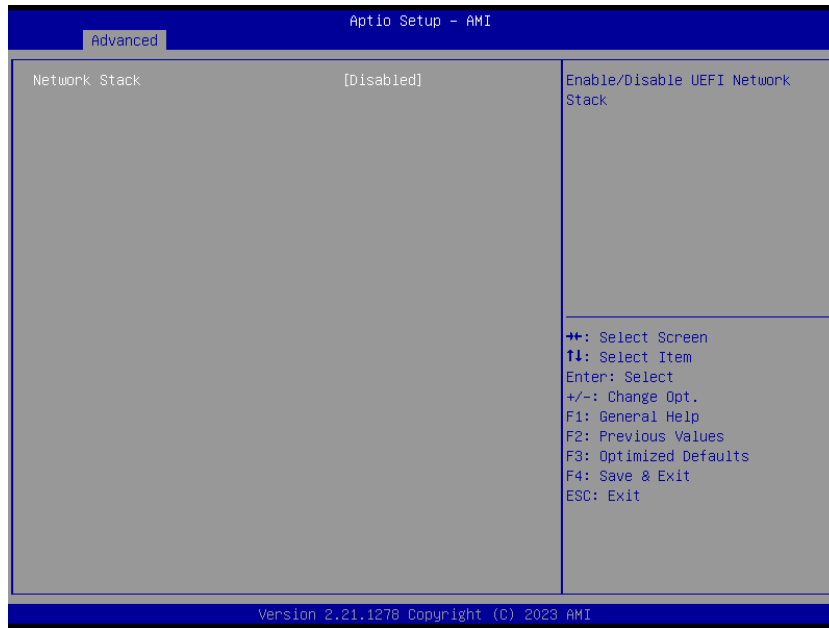

Item	Option	Description
Network Stack	Enabled Disabled[Default]	Enable/Disable UEFI Network Stack.

3.6.2.11 NVMe Configuration



3.6.3 Chipset

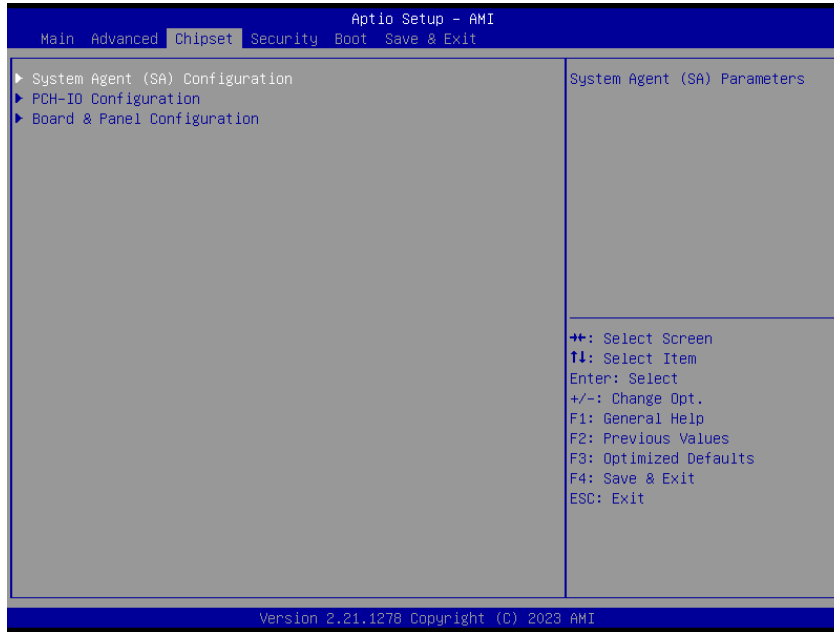

3.6.3.1 System Agent (SA) Configuration

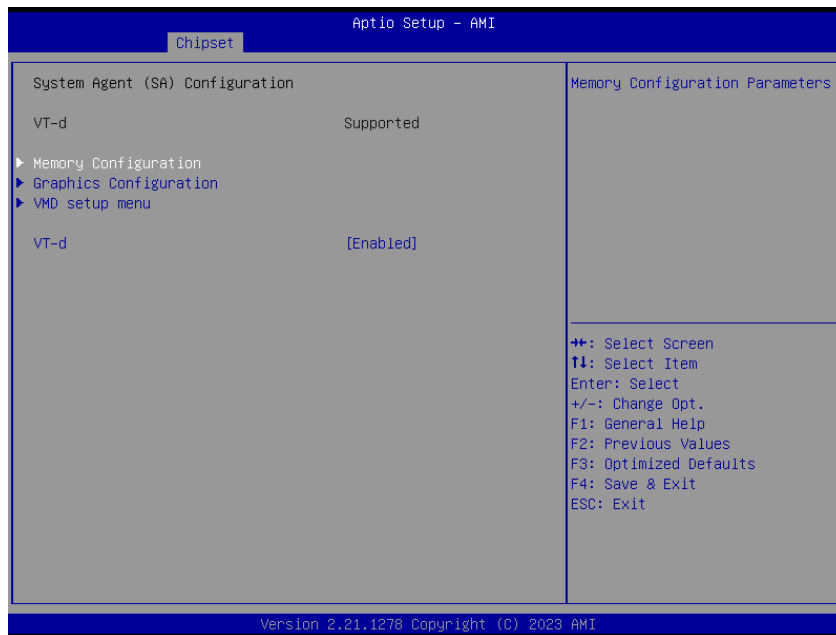

Item	Option	Description
VT-d	Disabled Enabled[Default]	VT-d capability.

3.6.3.1.1 Memory Configuration

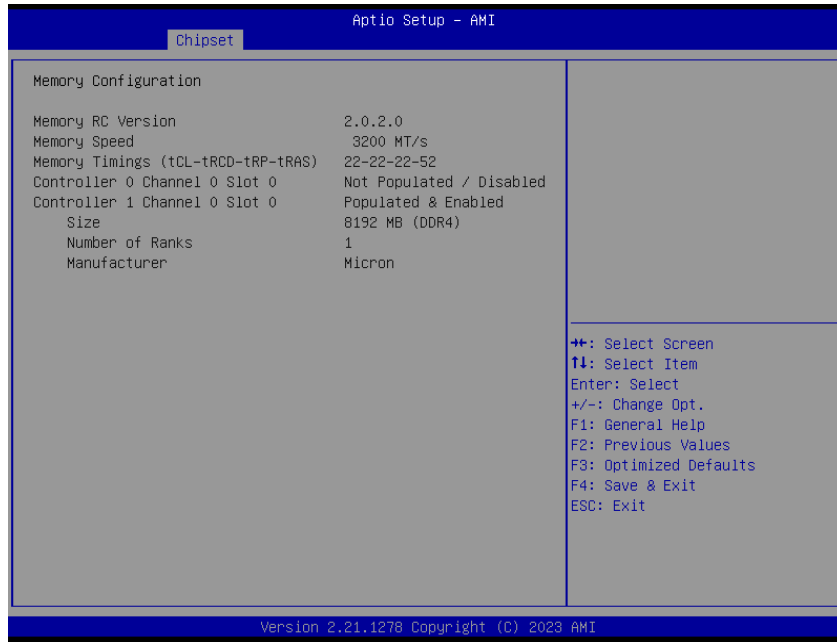

3.6.3.1.2 Graphics Configuration



Item	Option	Description
Primary Display	Auto[Default] IGFX	Select which of IGFX/PEG/PCI Graphics device should be Primary Display Or select HG for Hybrid Gfx.

3.6.3.1.3 VMD Configuration

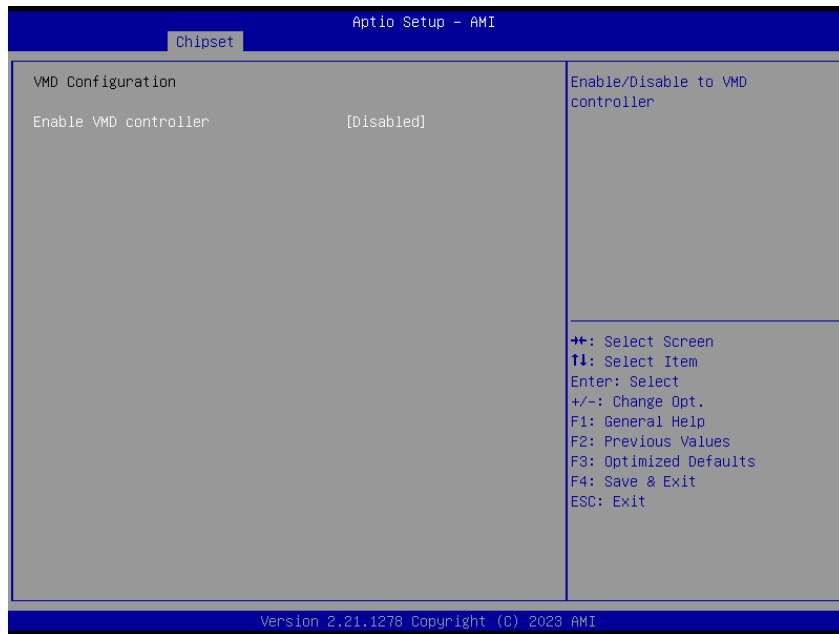

Item	Option	Description
Enable VMD controller	Disabled[Default] Enabled	Enable/Disable to VMD controller

3.6.3.2 PCH-IO Configuration



Item	Option	Description
PCH LAN Controller	Enabled[Default] Disabled	Enable/Disable onboard NIC.

3.6.3.2.1 PCI Express Configuration

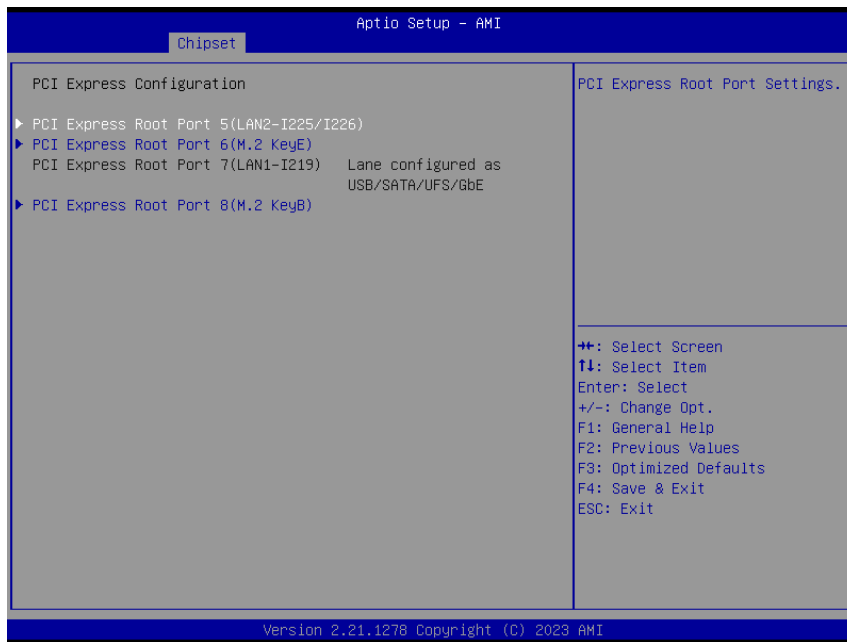

3.6.3.2.1.1 PCI Express Root Port 5(LAN2-I225/I226)

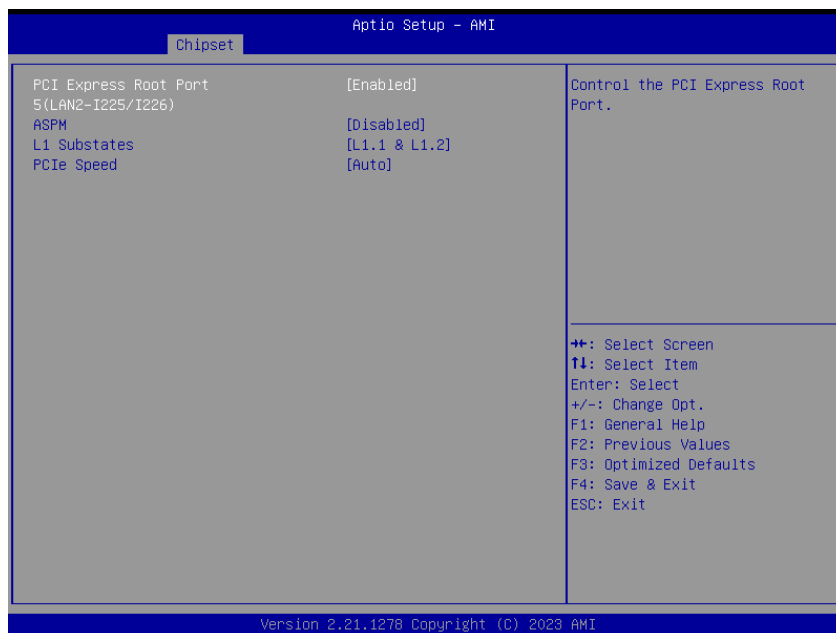

Item	Option	Description
PCI Express Root Port 5 (LAN2-I225/I226)	Disabled Enabled[Default],	Control the PCI Express Root Port.
ASPM	Disabled[Default] L0s L1 L0sL1 Auto	Set the ASPM Level: Force L0s – Force all links to L0s State AUTO – BIOS auto configure DISABLE – Disables ASPM.

L1 Substates	Disabled L1.1 L1.1 & L1.2[Default],	PCI Express L1 Substates settings.
PCIe Speed	Auto[Default] Gen1 Gen2 Gen3	Select PCIe speed.

3.6.3.2.1.2 PCI Express Root Port 6(M.2 KeyE)

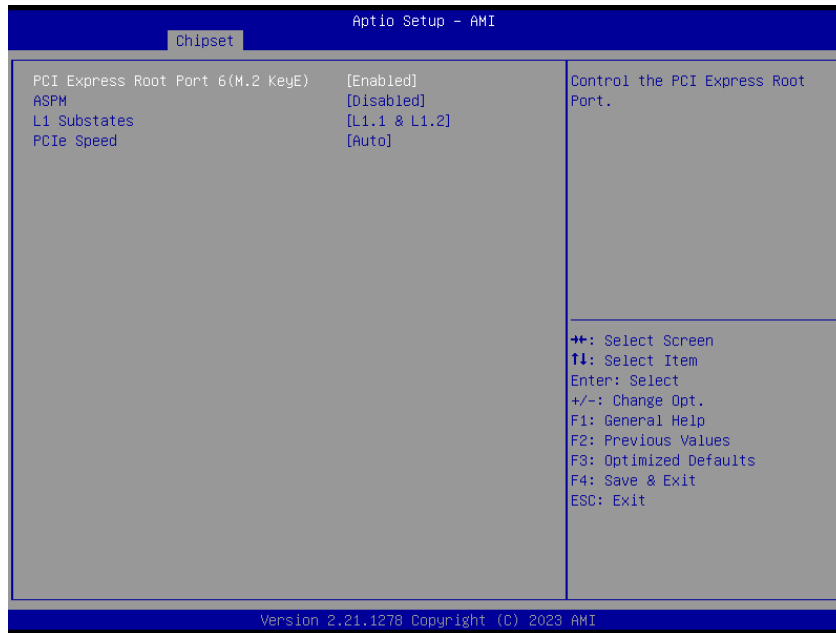

Item	Option	Description
PCI Express Root Port 6 (M.2 KeyE)	Disabled Enabled[Default],	Control the PCI Express Root Port.
ASPM	Disabled[Default] L0s L1 L0sL1 Auto	Set the ASPM Level: Force L0s – Force all links to L0s State AUTO – BIOS auto configure DISABLE – Disables ASPM.
L1 Substates	Disabled L1.1 L1.1 & L1.2[Default],	PCI Express L1 Substates settings.
PCIe Speed	Auto[Default] Gen1 Gen2 Gen3	Select PCIe speed.

3.6.3.2.1.3 PCI Express Root Port 8(M.2 KeyB)

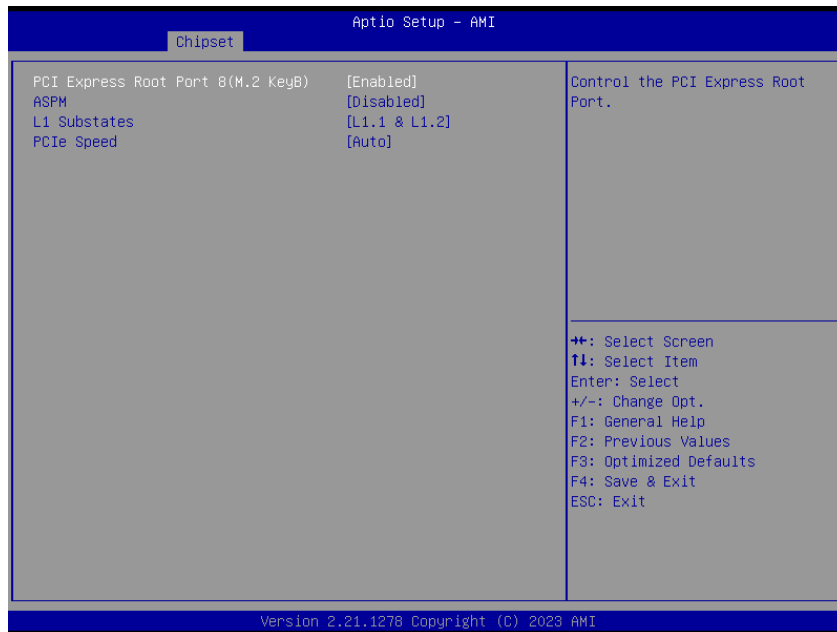

Item	Option	Description
PCI Express Root Port 8 (M.2 KeyB)	Disabled Enabled[Default],	Control the PCI Express Root Port.
ASPM	Disabled[Default] L0s L1 L0sL1 Auto	Set the ASPM Level: Force L0s – Force all links to L0s State AUTO – BIOS auto configure DISABLE – Disables ASPM.
L1 Substates	Disabled L1.1 L1.1 & L1.2[Default],	PCI Express L1 Substates settings.
PCIe Speed	Auto[Default] Gen1 Gen2 Gen3	Select PCIe speed.

3.6.3.2.2 SATA And RST Configuration

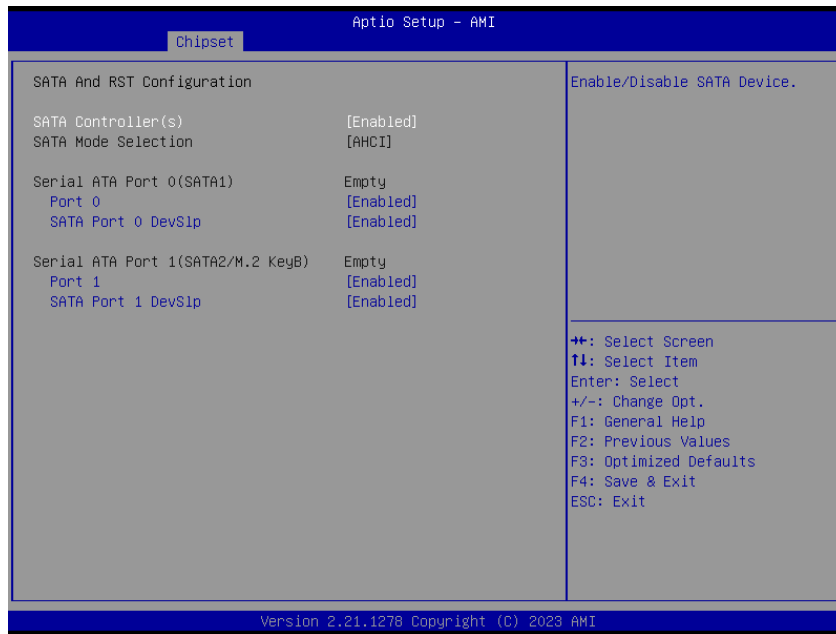

Item	Option	Description
SATA Controller(s)	Disabled Enabled[Default],	Enable/Disable SATA Device.
Port 0	Disabled Enabled[Default],	Enable or Disable SATA Port
SATA Port 0 DevSlp	Disabled Enabled[Default],	Enable/Disable SATA Port 0 DevSlp. For DevSlp to work, both hard drive and SATA port need to support DevSlp function, otherwise an unexpected behavior might happen. Please check board design before enabling it.
Port 1	Disabled Enabled[Default],	Enable or Disable SATA Port
SATA Port 1 DevSlp	Disabled Enabled[Default],	Enable/Disable SATA Port 1 DevSlp. For DevSlp to work, both hard drive and SATA port need to support DevSlp function, otherwise an unexpected behavior might happen. Please check board design before enabling it.

3.6.3.2.3 HD Audio Configuration

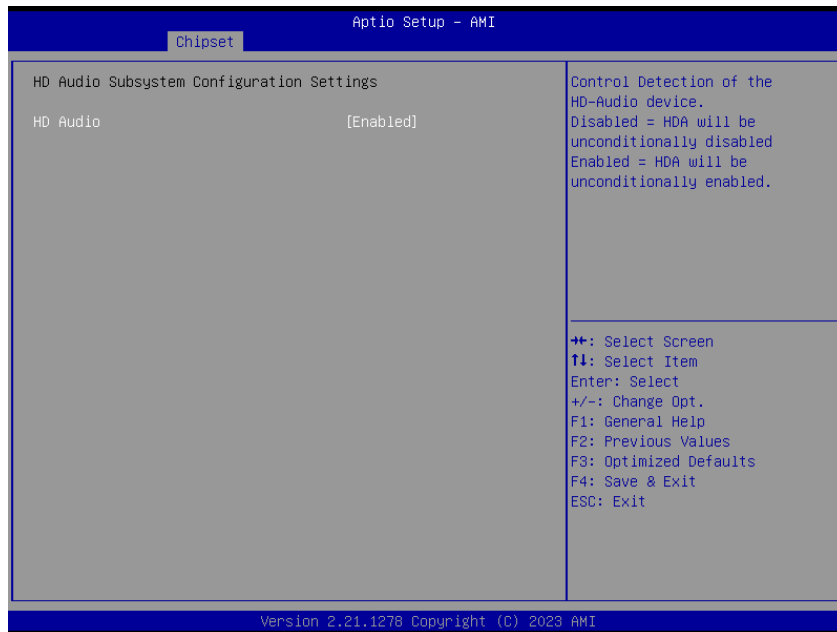

Item	Option	Description
HD Audio	Disabled Enabled[Default],	Control Detection of the HD-Audio device. Disable = HDA will be unconditionally disabled Enabled = HDA will be unconditionally enabled.

3.6.3.2.4 Board & Panel Configuration

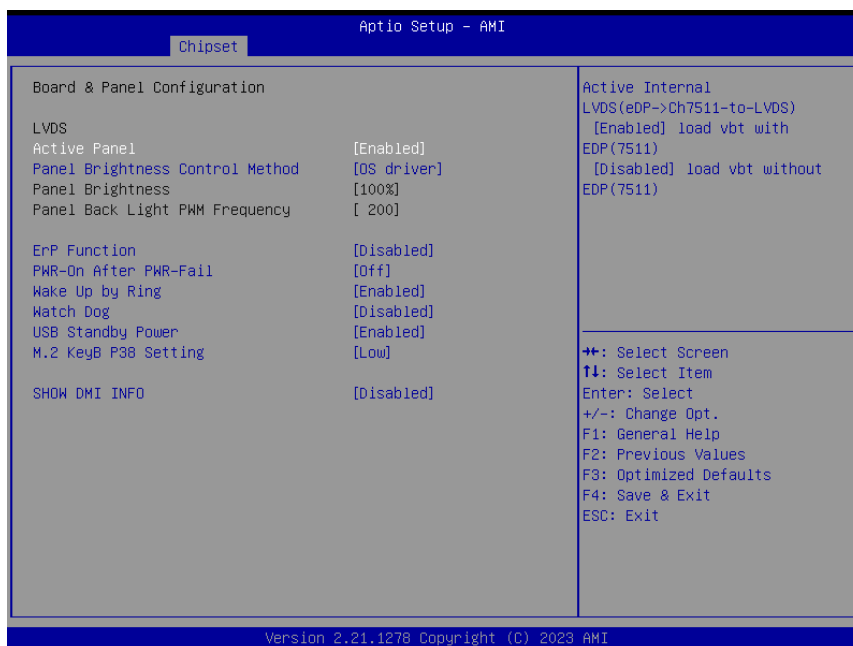

APC-2138

Item	Option	Description
Active Panel	Disabled Enabled[Default]	Active Internal LVDS(eDP->Ch7511-to-LVDS) [Enabled] load vbt with EDP(7511) [Disabled] load vbt without EDP(7511)
Panel Brightness Control Method	BIOS OS Driver[Default]	Panel Brightness Control Method. 1.BIOS 2.OS Driver
Panel Brightness	00% 25% 50% 75% 100%[Default]	Select Panel back light PWM duty.
Panel Back Light PWM Frequency	200[Default] 300 400 500 700 1k 2k 3k 5k 10k 20k	Select Panel back light PWM Frequency.
ErP Function	Disabled[Default], Enabled	ErP Function (Deep S5).
PWR-On After PWR-Fail	Off[Default], On Last State	AC loss resume.
Wake Up by Ring	Disabled Enabled[Default],	Wake Up by Ring from S3/S4/S5
Watch Dog	Disabled[Default], 30 sec 40 sec 50 sec 1 min 2 min 10 min 30 min	Select WatchDog.
USB Standby Power	Disabled Enabled[Default],	Enabled/Disabled USB Standby Power during S3/S4/S5
M.2 KeyB P38 Setting	Low[Default], High	Set M.2 KeyB Pin38(DEVSLP) as Low/High
SHOW DMI INFO	Disabled[Default], Enabled	SHOW DMI INFO

3.6.4 Security

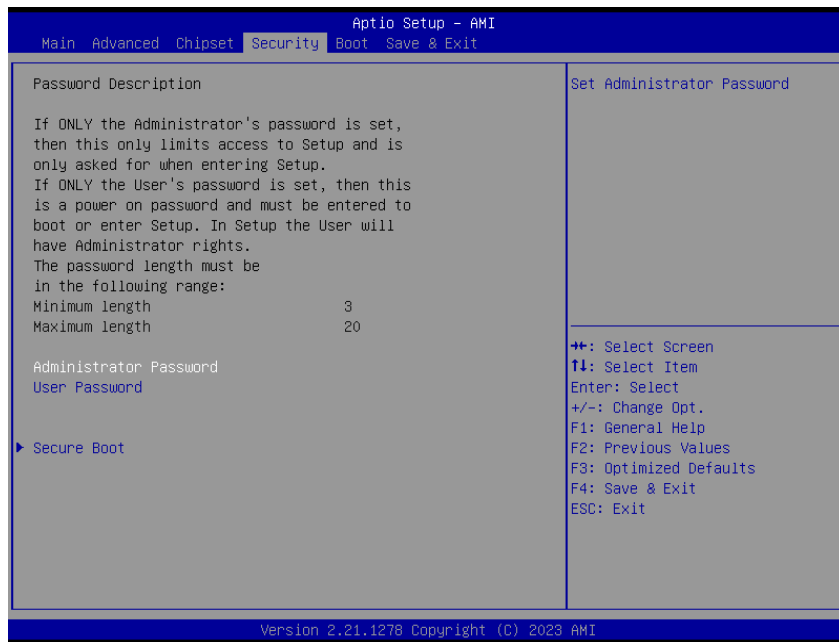

- **Administrator Password**

Set setup Administrator Password

- **User Password**

Set User Password

3.6.4.1 Secure Boot menu



Item	Option	Description
Secure Boot	Disabled Enabled[Default]	Secure Boot feature is Active if Secure Boot is Enabled, Platform Key(PK) is enrolled and the System is in User mode. The mode change requires platform reset
Secure Boot Mode	Standard[Default] Custom	Secure Boot mode options: Standard or Custom. In Custom mode, Secure Boot Policy variables can be configured by a physically present user without full authentication

3.6.5 Security

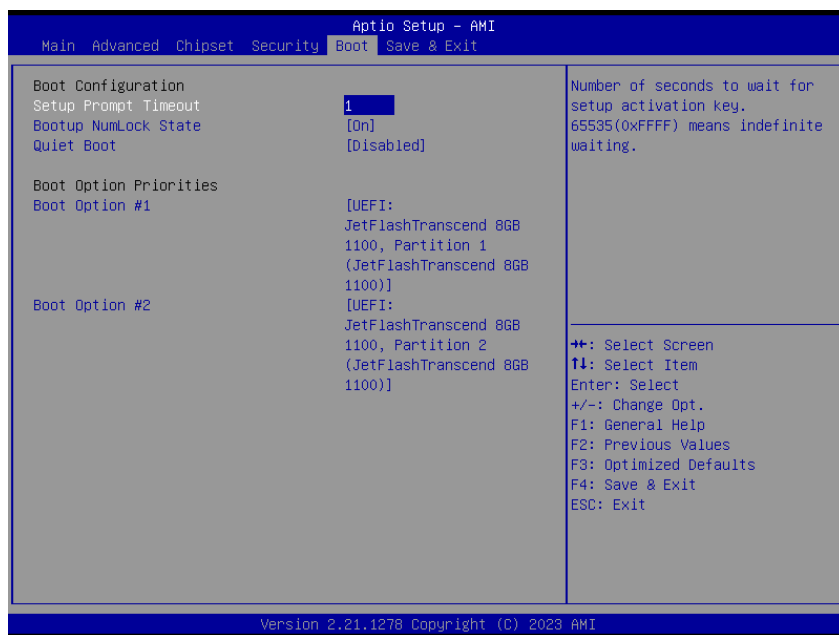

Item	Option	Description
Setup Prompt Timeout	1	Number of seconds to wait for setup activation key. 65535(0xFFFF) means indefinite waiting.
Bootup NumLock State	On[Default] Off	Select the Keyboard NumLock state
Quiet Boot	Disabled[Default] Enabled	Enables or disables Quiet Boot option
Boot Option #1	Set the system boot order.	
Boot Option #2	Set the system boot order.	

3.6.6 Save and exit

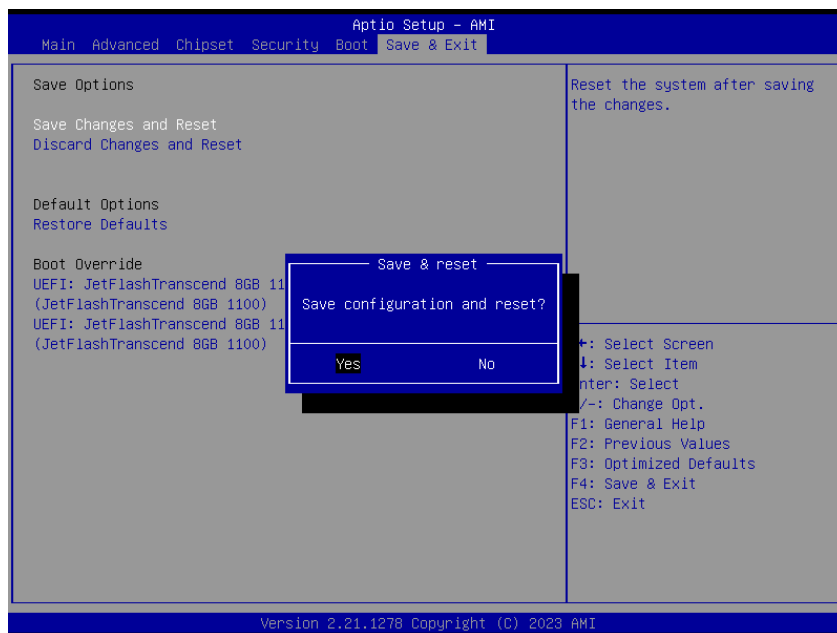
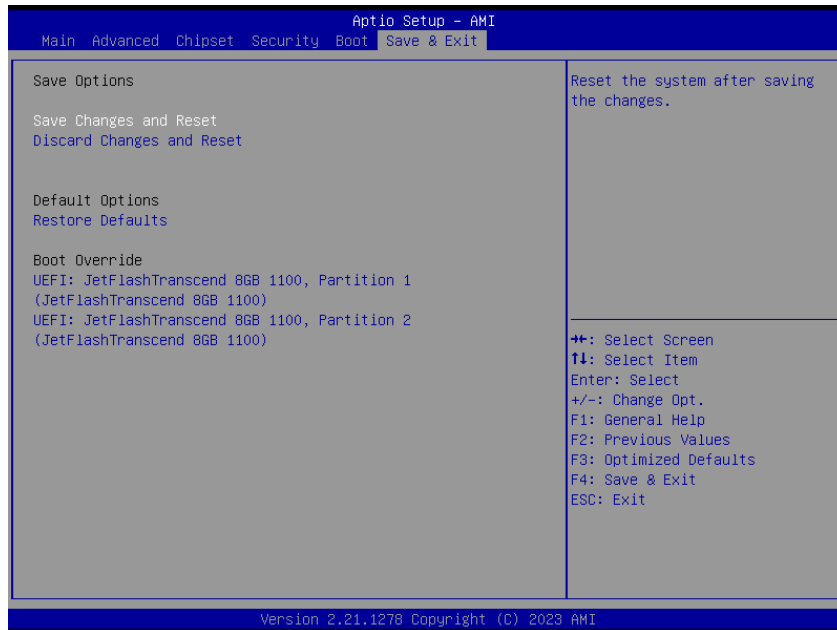

3.6.6.1 Save Changes and Reset

Reset the system after saving the changes.

3.6.6.2 Discard Changes and Reset

Reset system setup without saving any changes.

3.6.6.3 *Restore Defaults*

Restore/Load Default values for all the setup options.

3.6.6.4 *Launch EFI Shell from filesystem device*

Attempts to Launch EFI Shell application (Shell.efi) from one of the available filesystem devices.

4. Drivers Installation



Note: Installation procedures and screen shots in this section are for your reference and may not be exactly the same as shown on your screen.

4.1 Install Chipset Driver

All drivers can be found on the Avalue Official Website:

<http://www.avalue.com.tw>.



Note: The installation procedures and screen shots in this section are based on Windows 10 operation system. If the warning message appears while the installation process, click Continue to go on.

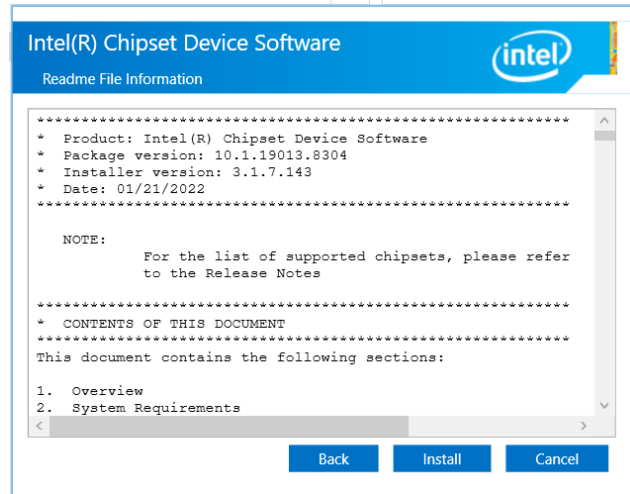

Step 3. Click Install.

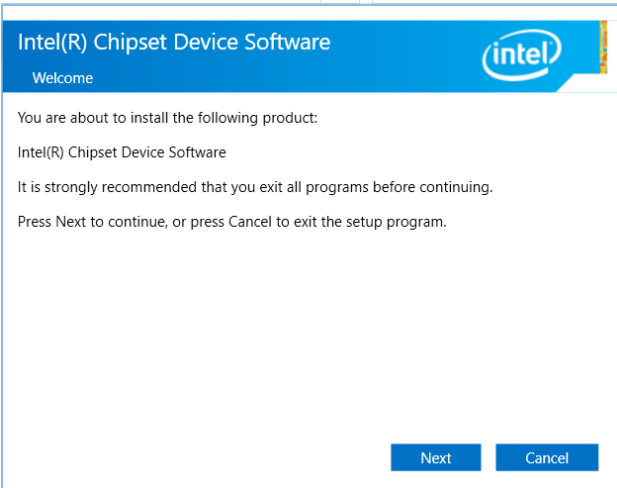

Step 1. Click Next.

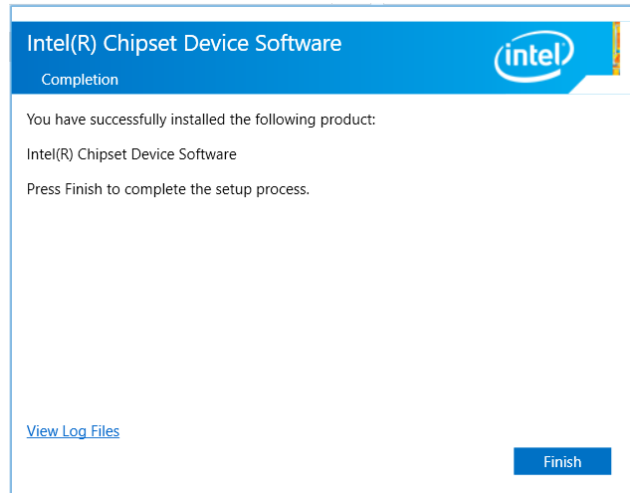

Step 4. Complete setup.

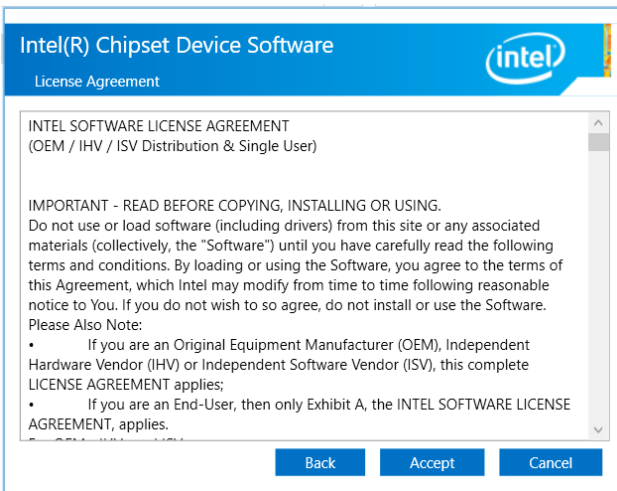

Step 2. Click Accept.

4.2 Install VGA Driver

All drivers can be found on the Avalue Official Website:

<http://www.avalue.com.tw>.



Note: The installation procedures and screen shots in this section are based on Windows 10 operation system. If the warning message appears while the installation process, click Continue to go on.

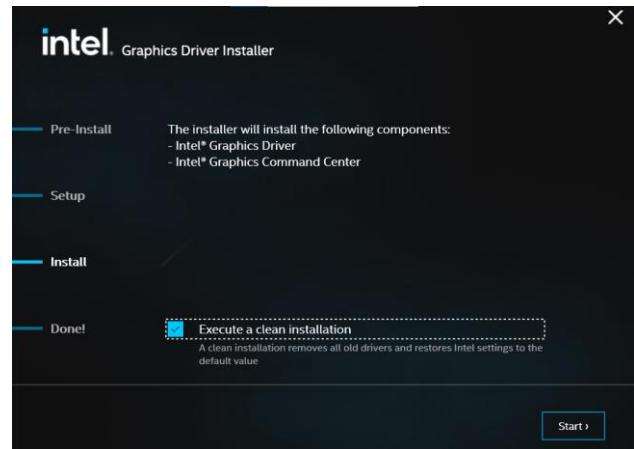

Step 3. Click Start.



Step 1. Click Begin installation.

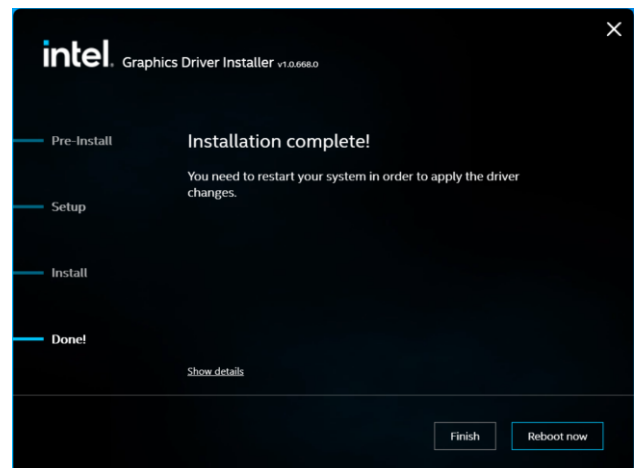

Step 4. Click Reboot now.

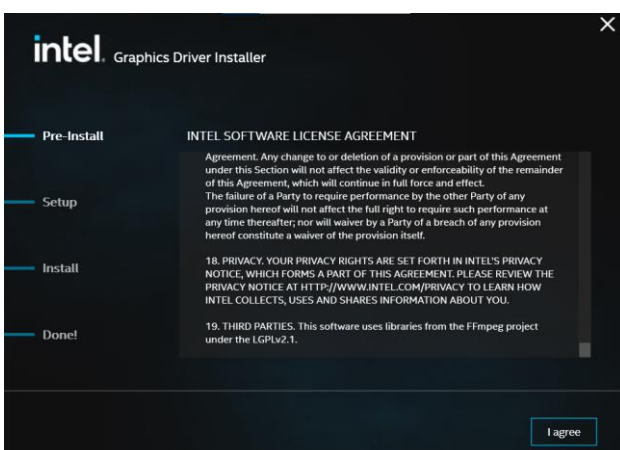

Step 2.
Click **Next** to accept license agreement.

4.3 Install Serial IO Driver

All drivers can be found on the Avalue Official Website:

<http://www.avalue.com.tw>.



Note: The installation procedures and screen shots in this section are based on Windows 10 operation system. If the warning message appears while the installation process, click Continue to go on.

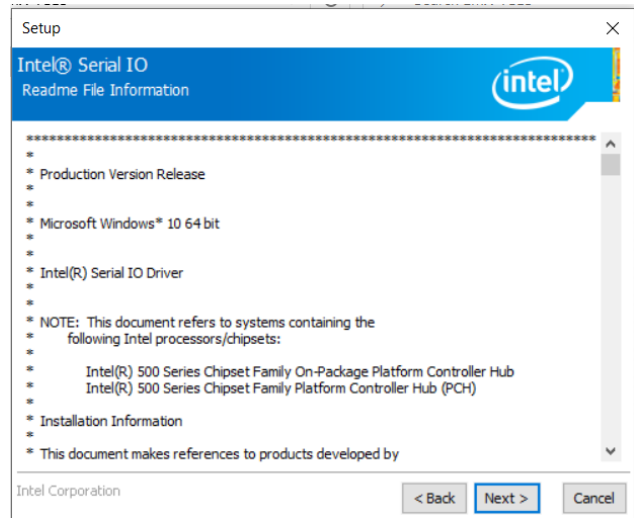

Step 3. Click Next.



Step 1. Click Next to continue setup.

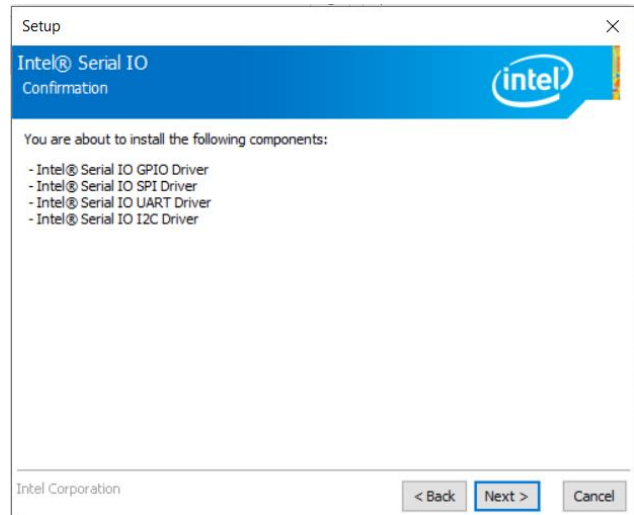

Step 4. Click Next.



Step 2. Click Next.

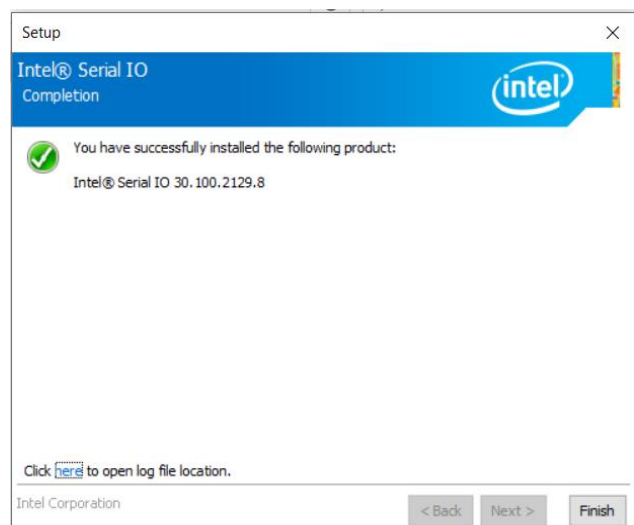

Step 5. Click Finish to complete the setup.

4.4 Install ME Driver

All drivers can be found on the Avalue Official Website:

<http://www.avalue.com.tw>.



Note: The installation procedures and screen shots in this section are based on Windows 10 operation system. If the warning message appears while the installation process, click Continue to go on.

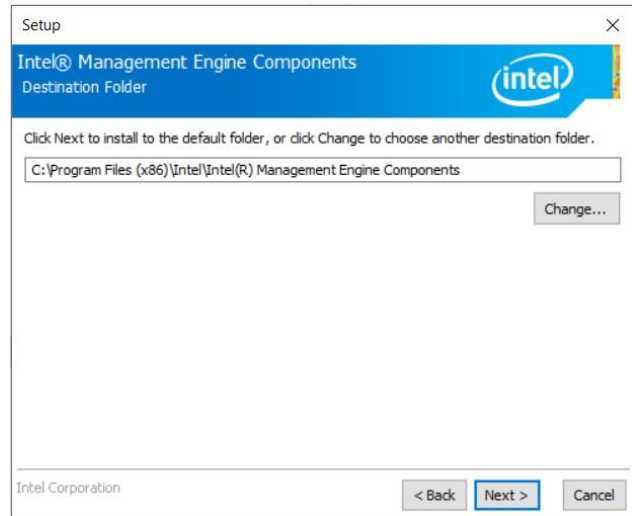

Step 3. Click Next.

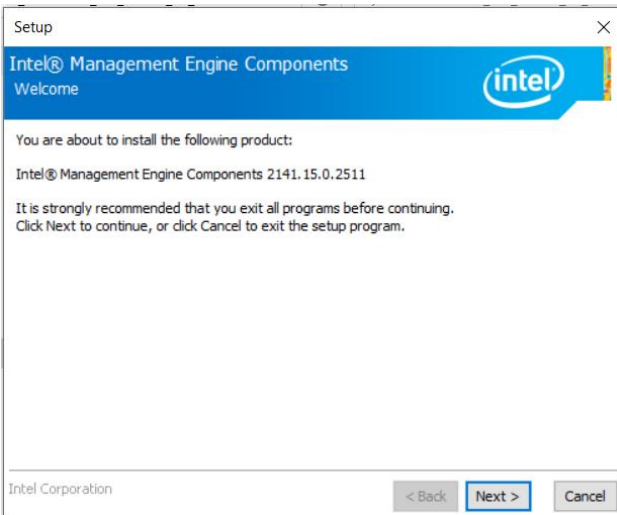

Step 1. Click Next to continue setup.

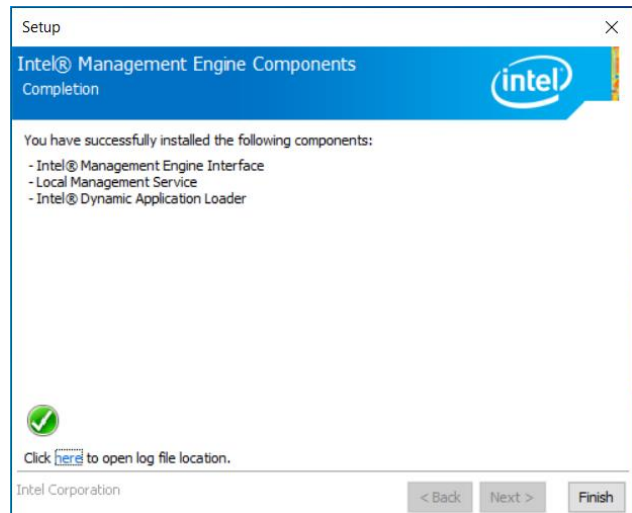

Step 4. Click Finish to complete setup.



Step 2. Click Next.

4.5 Install Audio Driver (For Realtek ALC897 and ALC888S HD Audio)

All drivers can be found on the Avalue Official Website:

<http://www.avalue.com.tw>.



Note: The installation procedures and screen shots in this section are based on Windows 10 operation system. If the warning message appears while the installation process, click Continue to go on.

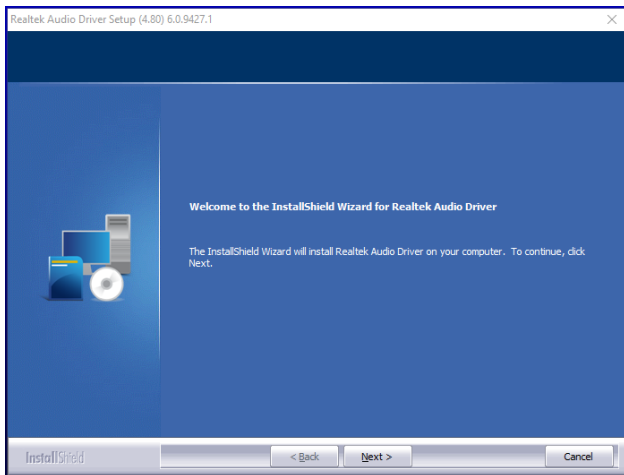

Step1. Click **Next** to Install.

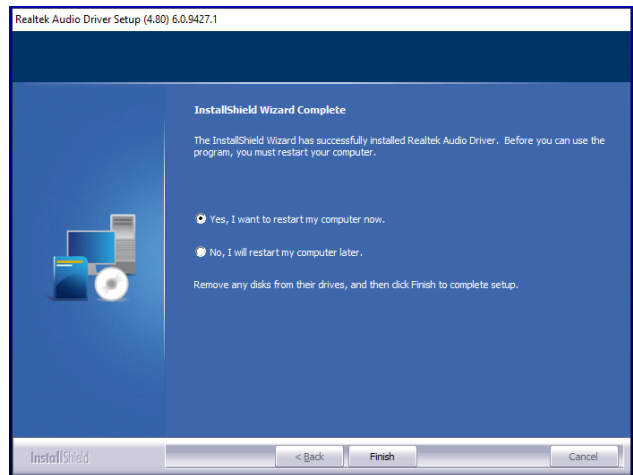

Step 2. Click **Finish** to complete setup.

4.6 Realtek Audio Console

All drivers can be found on the Avalue Official Website:

<http://www.avalue.com.tw>.



Note: The installation procedures and screen shots in this section are based on Windows 10 operation system. If the warning message appears while the installation process, click Continue to go on.

```
Administrator: Command Prompt
C:\>cd C:\Users\EMX-TGLC_RAID0\Desktop\EMX-TGLC\Realtek_Audio_UI_Win10_64_1.38.277.0\RtkUWP_1.38.277.0_x64_bundle_ReleaseSign.appxupload_Windows10
C:\Users\EMX-TGLC_RAID0\Desktop\EMX-TGLC\Realtek_Audio_UI_Win10_64_1.38.277.0\RtkUWP_1.38.277.0_x64_bundle_ReleaseSign.appxupload_Windows10>
```

Step1.

```
Administrator: Command Prompt - DISM_INSTALL_RtkUWP_V3.bat
C:\Users\EMX-TGLC_RAID0\Desktop\EMX-TGLC\Realtek_Audio_UI_Win10_64_1.38.277.0\RtkUWP_1.38.277.0_x64_bundle_ReleaseSign.appxupload_Windows10>DISM_INSTALL_RtkUWP_V3.bat
Deployment Image Servicing and Management tool
Version: 10.0.19041.044
Image Version: 10.0.19043.928
The operation completed successfully.
Press any key to continue . . .
```

Step 3.

```
Administrator: Command Prompt
C:\Users\EMX-TGLC_RAID0\Desktop\EMX-TGLC\Realtek_Audio_UI_Win10_64_1.38.277.0\RtkUWP_1.38.277.0_x64_bundle_ReleaseSign.appxupload_Windows10>DISM_INSTALL_RtkUWP_V3.bat
```

Step 2.

4.7 Install LAN Driver

All drivers can be found on the Avalue Official Website:

<http://www.avalue.com.tw>.



Note: The installation procedures and screen shots in this section are based on Windows 10 operation system. If the warning message appears while the installation process, click Continue to go on.

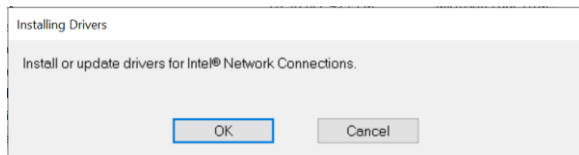

Step 1. Click OK.

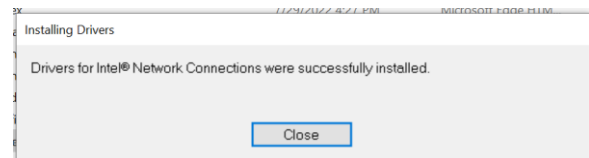

Step 2. Click Close.

4.8 Install RST for RAID Driver

All drivers can be found on the Avalue Official Website:
<http://www.avalu.com.tw>.



Note: The installation procedures and screen shots in this section are based on Windows 10 operation system. If the warning message appears while the installation process, click Continue to go on.

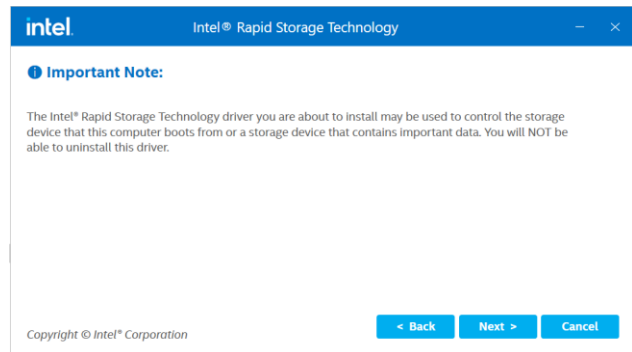

Step 3. Click Next.

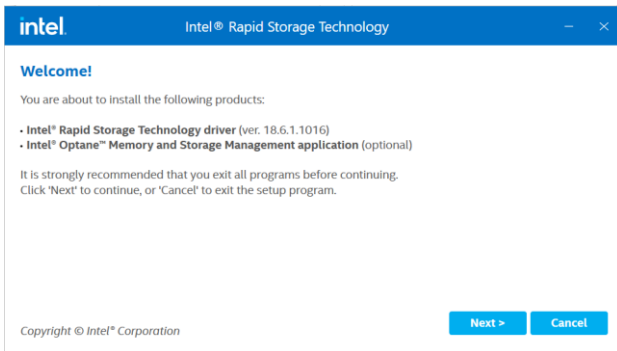

Step 1. Click Next to continue installation.

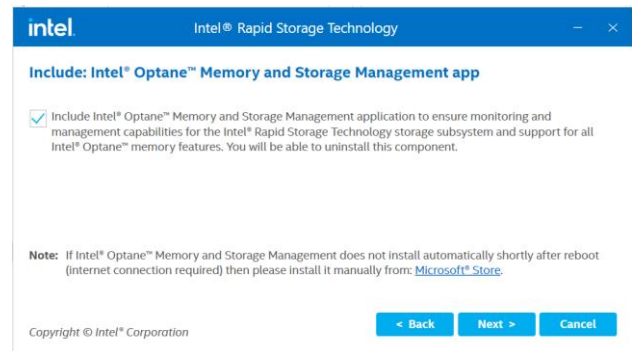

Step 4. Click Next.

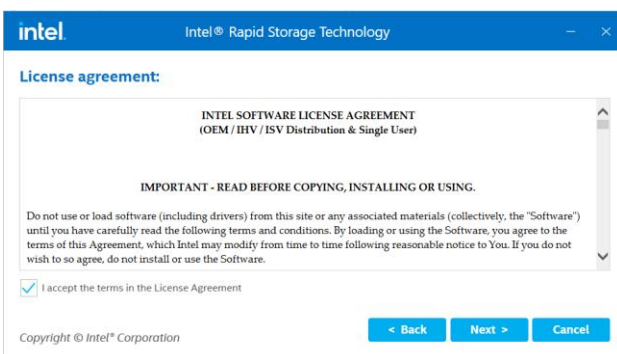

Step 2. Click Next.

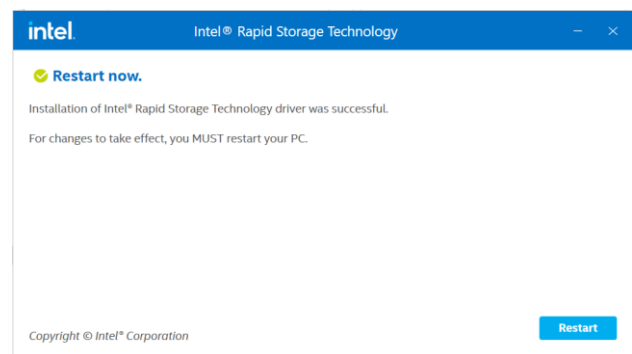

Step 5. Complete setup.

